

Quickstart guide for Pump installation and motor connection

Before installing the pump, all piping should be flushed out so as to eliminate all dirt, grease or possible other particles. It is recommended to temporarily mount a gauze filter at the pump inlet.

Installation

The pump can be mounted in both horizontal and vertical piping. However, the electric motor should always be in horizontal position. When installing the pump, proceed as follows:

1. Make sure the piping is supported before and after the pump (brackets).
2. The arrow on the pump casing shows the exact position of the suction and delivery flange.
3. Check the exact position of the terminal box on the electric motor in relation to the position of the pump in the piping. If this position is not correct, the stator should be turned. See also the section in the Instruction Manual: dismantling and mounting.
4. Mount the flange gaskets and place the pump between the flanges of the piping.
5. Insert the fastening bolts and nuts and tighten them crosswise.

Connecting the electric motor

Before connecting the electric motor to the mains consult the prevailing regulations of the local electricity company (European standard EN 60204-1).

Other important points to be observed:

- Always use a thermal motor safety switch.
- If possible, mount a working switch as close as possible to the pump.
- It is recommended to mount an earth leakage circuit breaker.

On the type plate of the electric motors you will find one of the following voltage data

- 230/400V 50Hz (277/480V 60Hz) up to and incl. 1,5 kW.
- 400/695V 50Hz (480/830V 60Hz) from 2,2 kW and higher.

Consult your supplier in case of deviating voltages or mains frequencies.

230/400 V

These motors can be connected in star to a mains of 400 V between the phases (see figure 1).

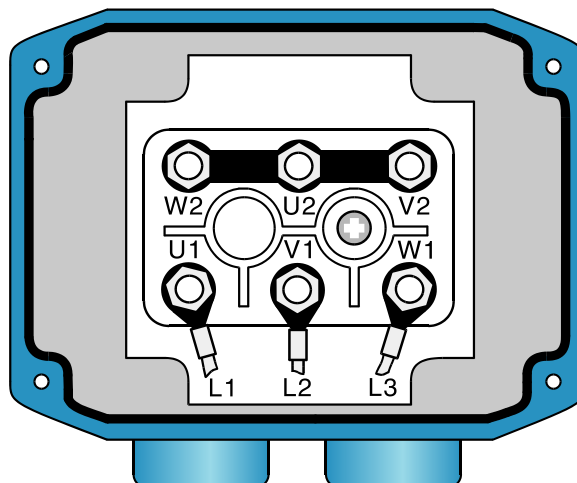

figure 1 Star connection

400/695 V

These motors should be connected in delta to a mains of 400 V between the phases (see figure 2).

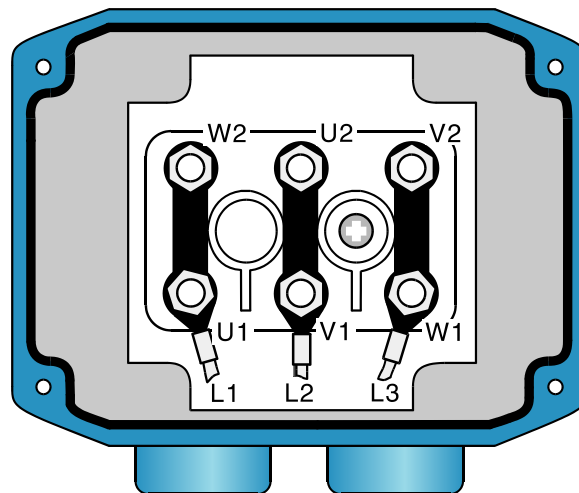

figure 2 Delta connection

Motors with a power of 2,2 kW and more should usually not be connected in delta directly (the starting current will raise too much immediately after starting the motor). So, the motor is first connected in star and after a few seconds when it has reached the required speed, it is converted to delta by means of a star-delta switch. (see figure 3).

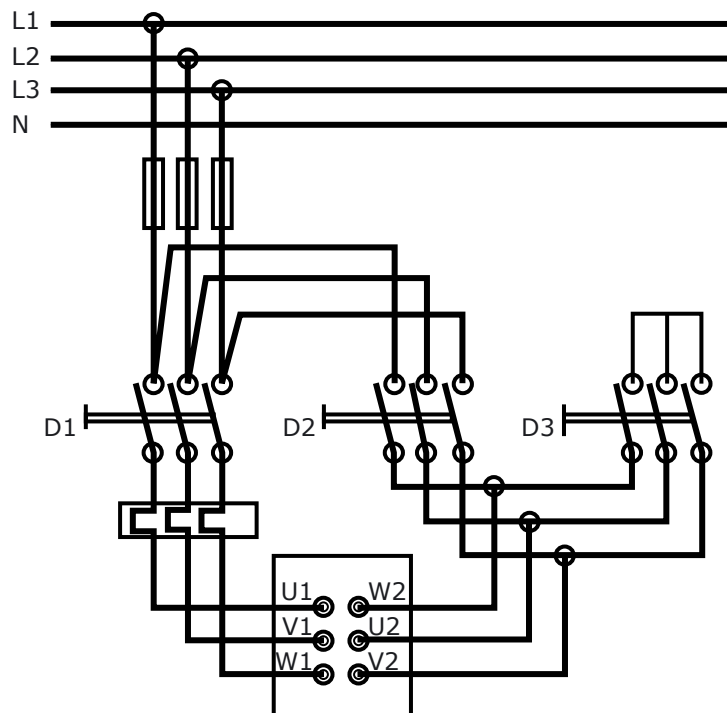

figure 3 Star-delta switch



JOHNSON PUMP

Johnson Pump Horticulture

De Hondert Margen 23 • 2678 AC De Lier • The Netherlands

Tel. +31 (0)174 51 84 10

Fax. +31 (0)174 51 84 44

horticulture@johnson-pump.com

www.johnson-pump.com/Horticulture