



JOHNSON PUMP
AN SPX BRAND

Combi Modular System

Standardised centrifugal pumps



EN 733

EN 22858

ISO 5199

API 610

SPX[®]

Johnson Pump's water, chemical and petrochemical standardised pumps represent a range of horizontal centrifugal pumps designed and manufactured in our plants in accordance with EN 733 (DIN 24255), ISO 5199 & EN 22858 (ISO 2858 / DIN 24256) or API 610.

A characteristic of our standardised pumps is the large number of material, shaft seal and bearing system options available. This allows us to offer a pump nearly tailor-made for your application using standard components.

Our modular design provides for maximum interchangeability of components between the variants and also with other pump types of the Combi system; thereby greatly limiting the number of spare parts to be kept in stock.

Our CE and ATEX certified pumps can be delivered from our plants as single pumps, pump units with motors, baseplate-mounted pump units and OEM units.

EN 733

(DIN 24255)

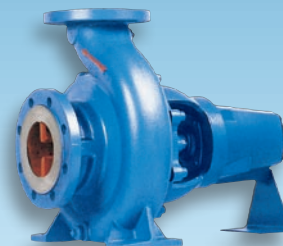

Technical Data

Max. capacity:	1500 m ³ /h
Max. head:	100 m
Max. system pressure:	10 bar
Max. temp.:	200°C
Max. speed:	3600 rpm

Materials

	Pump casing	Pump cover	Impeller	Shaft	Shaft sleeve
Cast iron	x	x	x	-	-
Nodular cast iron	x	x	-	-	-
Bronze	x	x	x	-	x
Stainless steel	-	-	x	x	x
Alloy	-	-	-	x	x

Johnson Pump's water standardised pump represents a range of horizontal centrifugal pumps ideal as utility or general purpose pumps. The pump is designed to EN 733 (DIN 24255); however, it has a wider hydraulic field due to a larger number of available sizes.

Flange dimensions, bolt circle and number of holes comply with ISO 7005 PN 10 / PN 16 (ISO 7005 ≈ EN 1092-2 (DIN 2533)).

The pump is driven by a standard IEC foot motor. The power is transmitted through a standard or spacer coupling.

Handles all types of low viscosity, clean or slightly contaminated liquids.

Application fields

- Industry as a general purpose pump
- Utility as a general duty, circulation or water treatment pump
- Agriculture and Horticulture as irrigation and circulation heating pumps

ISO 5199

EN 22858

(ISO 2858 / DIN 24256)



Technical Data

Max. capacity:	800 m ³ /h
Max. head:	160 m
Max. system pressure:	16 bar
Max. temp.:	200°C
Max. speed:	3600 rpm

Materials					
	Pump casing	Pump cover	Impeller	Shaft	Shaft sleeve
Cast iron	x	x	x	-	-
Nodular cast iron	x	x	-	-	-
Bronze	x	x	x	-	x
Stainless steel	x	x	x	x	x
Alloy	-	-	-	x	x

Johnson Pump's chemical standardised pump complies entirely to ISO 5199, which comprises important technical guidelines for "Chemical pumps" to ensure optimal reliability.

The pump represents a range of horizontal centrifugal pumps, designed to EN 22858 (ISO 2858 / DIN 24256) for heavy duty applications as a process pump in the chemical industry.

Flange dimensions, bolt circle and number of holes comply with ISO 7005 PN 16. The pumps are also available with flanges according to ANSI B16.5-150 lbs (ISO 7005 PN 20).

The pump is driven by a standard IEC foot motor. The power is transmitted through a standard or spacer coupling.

Handles all types of low viscosity, clean or slightly contaminated liquids.

Application fields

- Chemical industry as an ISO 5199 compliant pump
- Industry as a heavy duty general purpose pump

API 610



Technical Data

Max. capacity:	350 m ³ /h
Max. head:	160 m
Max. system pressure:	35 bar
Operating temp. range:	-30°C – +350°C
Max. viscosity:	300 mm ² /s
Max. speed:	3600 rpm

Materials combinations API 610 code S-1, S-6, S-8, C-6, A-8					
	Pump casing	Pump cover	Impeller	Shaft	Bearing bracket
Cast iron	-	-	x	-	-
Nodular cast iron	-	-	-	-	x
Carbon steel	x	x	-	-	x
13% Cr-steel	x	x	x	-	-
Stainless steel (316)	x	x	x	x	-
Alloy steel	-	-	-	x	-

other materials upon request

Johnson Pump's petrochemical standardised pump represents a range of horizontal centerline supported centrifugal pumps, designed to API 610 standards and to API 682 seal standards for heavy duty applications as a process pump in the petrochemical industry.

The construction easily meets the requirements laid down in American Petroleum Institute standard "Centrifugal Pumps For General Refinery Service", API 610.

Flange dimensions, bolt circle and number of holes comply with ISO 7005 PN 50 or PN 20 (ANSI B16.5 300 lbs–150 lbs).

Fully integrated design of pump, IEC motor, API 610 compliant baseplate and accessories.

Handles all types of low viscosity, clean or slightly contaminated liquids.

Application fields

- (Petro)Chemical industry and refineries as an API 610 compliant pump
- Industry as a heavy duty general purpose pump

Combi Modular System

The Combi system is a modular programme of single stage centrifugal pumps with a high degree of interchangeability of parts between the different pump constructions.

The Combi pumps cover an extensive series of centrifugal pumps which can be supplied as horizontal, vertical and submerged pumps. A number of standards were taken into account in the designing of this pump series; EN 733 (DIN 24255), EN 22858 (ISO 2858/DIN 24256), ISO 5199 and API610.

Component modules

The Combi system design can be subdivided into a number of modules:

- bearing unit
- shaft seal
- shaft diameter
- nominal impeller diameter
- hydraulics (impeller/volute combination)

Always the right pump

The modular design makes it possible to construct many design variants and it also provides a large degree of interchangeability of components between various pump types and even between the different pump families. This, together with the wide range of materials available, makes it easy to supply the correct design for each specific application; allowing customers to be served in an optimal way.

Spare parts and maintenance

The high interchangeability in spare parts between different sizes and even pump families greatly limits spare parts stock levels.

Maintenance is simple in all the Combi models thanks to the use of standard components and the Back-Pull-Out principle.

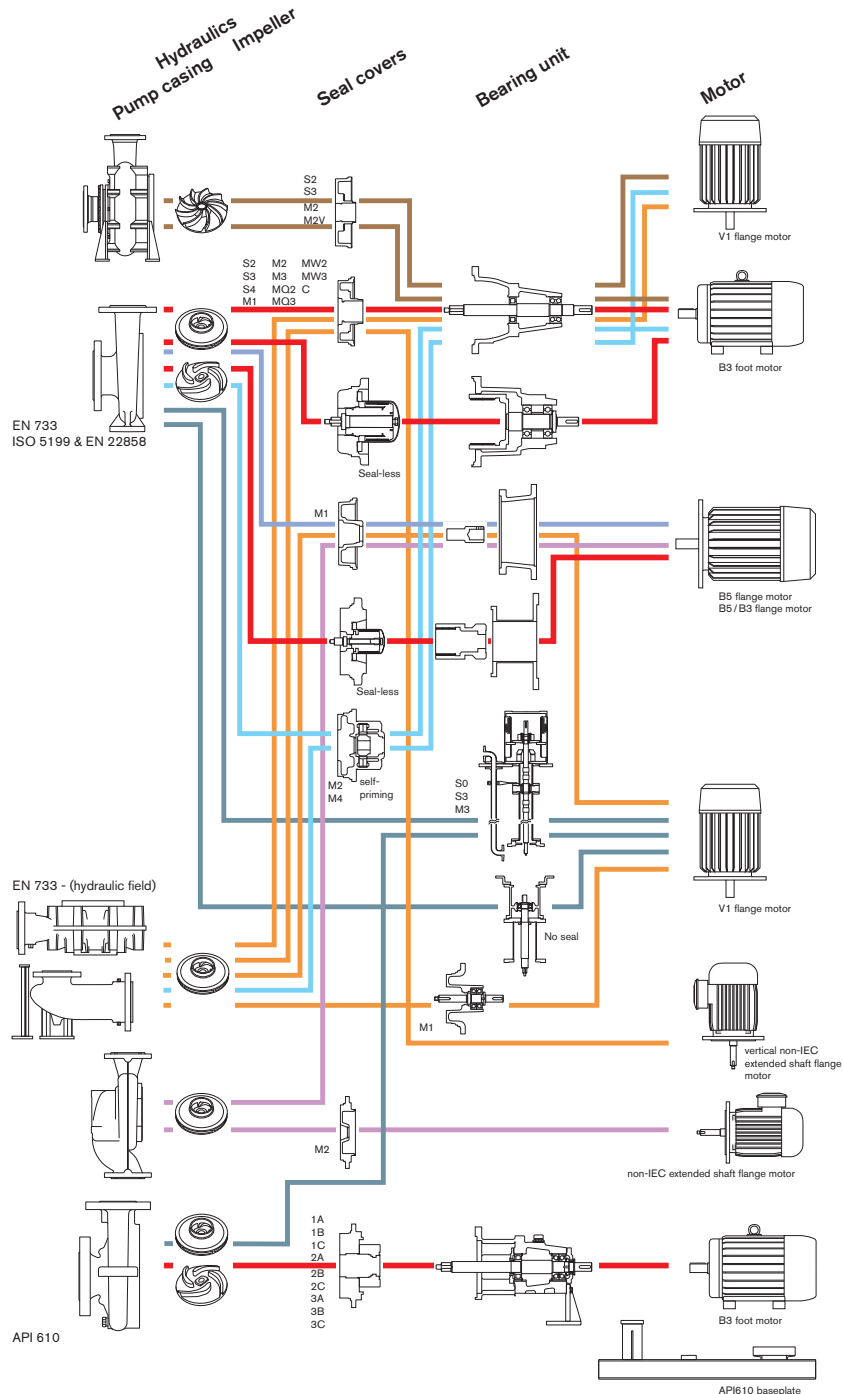

- | | | | |
|--|--------------------------|--|--------------------------|
| | Solids & gaseous content | | Submerged with dry motor |
| | Standardised pumps | | Vertical |
| | Compact monobloc | | InLine |
| | Self-priming | | |

Shaft sealing

- S0 Oil seal
- S2 Soft packing, shaft sleeve
- S3 Soft packing, shaft sleeve, lantern ring
- S4 Soft packing, shaft sleeve, cooling jacket
- M1 Mechanical seal, unbalanced
- M2 Mechanical seal, unbalanced, shaft sleeve
- M2V Mechanical seal, unbalanced, shaft sleeve, oil quench, integrated venturi system
- M3 Mechanical seal, balanced, shaft sleeve
- M4 Lip seals, shaft sleeve
- MQ2 Mechanical seal, unbalanced, dry-run protection/pressure-less quench, shaft sleeve
- MQ3 Mechanical seal, balanced, dry-run protection/pressure-less quench, shaft sleeve
- MW2 Mechanical seal, unbalanced, heating/cooling jacket, shaft sleeve
- MW3 Mechanical seal, balanced, heating/cooling jacket, shaft sleeve
- C Cartridge seal assemblies
- Seal-less
- Magnetic drive

Mechanical shaft seals according to API 682

- 1A Single seal arrangement 1 type A, pusher type seal
- 1B Single seal arrangement 1 type B, metal bellows rotating flexible element
- 1C Single seal arrangement 1 type C, metal bellows stationary flexible element
- 2A Arrangement 2 Dual seal with unpressurized buffer lower than product type A, pusher type seal
- 2B Arrangement 2 Dual seal with unpressurized buffer lower than product type B, metal bellows rotating flexible element
- 2C Arrangement 2 Dual seal with unpressurized buffer lower than product type C, metal bellows stationary flexible element
- 3A Arrangement 3 Dual seal with pressurized buffer higher than product type A, pusher type seal
- 3B Arrangement 3 Dual seal with pressurized buffer higher than product type B, metal bellows rotating flexible element
- 3C Arrangement 3 Dual seal with pressurized buffer lower than product type C, metal bellows stationary flexible element

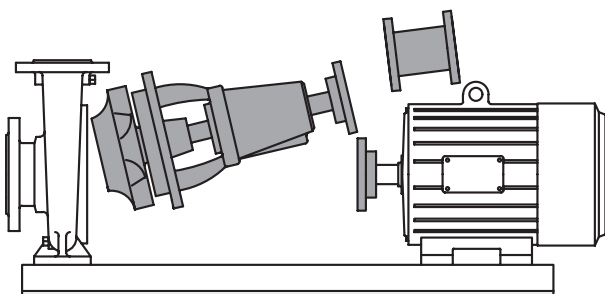

Service friendly with Back-Pull-Out

Shaft sealing

Stuffing box packings – standard type

S2

Soft packing ring, shaft sleeve

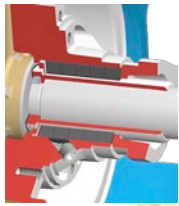

S3

Soft packing ring, shaft sleeve, lantern ring

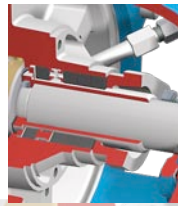

S4

Soft packing ring, shaft sleeve, cooling jacket

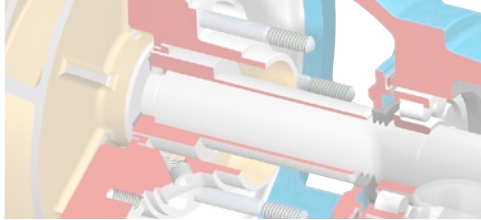
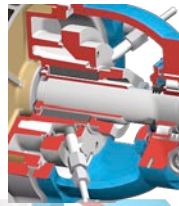

Mechanical seals – according to EN 12756 (DIN 24960)

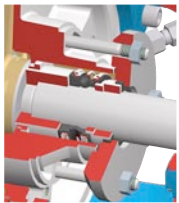

M1

Single mechanical seal, unbalanced



M2 MG12 / M7N

Single mechanical seal, unbalanced, shaft sleeve



M3 HJ92N / HJ977GN

Single mechanical seal, balanced, shaft sleeve



MQ2 MG12 / M7N

Single mechanical seal, unbalanced, dry-running protection or pressure-less quench, shaft sleeve



MQ3 HJ92N / HJ977GN

Single mechanical seal, balanced, dry-running protection or pressure-less quench, shaft sleeve

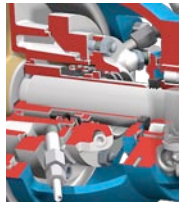

MW2 MG12 / M7N

Single mechanical seal, unbalanced, cooling/heating jacket, shaft sleeve

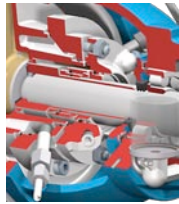

MW3 HJ92N / HJ977GN

Single mechanical seal, balanced, cooling/heating jacket, shaft sleeve

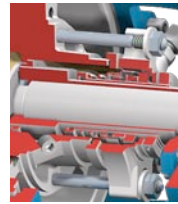

Cartridge seals

single, single with quench and double seals

Mechanical seals – according to API 682

The seal chamber of our API 610 standardised pumps is designed to fit all types of seals, especially API 682 cartridge seals.

Seal-less

Ideal for the clean, safe and economical pumping of hazardous or expensive liquids. Handles all types of low viscosity, clean or slightly contaminated non-magnetic and aggressive liquids.

The seal-less options are available in two versions; as a frame-mounted, long coupled magnetic drive and as a space-saving, close-coupled magnetic drive.

Easily retrofitted to existing Combi standardised pumps. Johnson Pump seal-less solutions for the Combi series are easy to maintain and are ATEX certified.

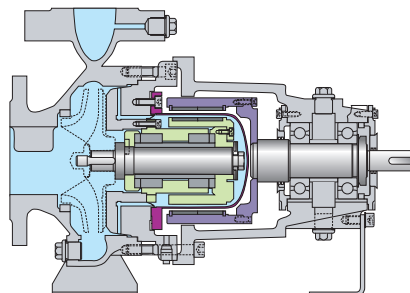

Frame mounted long-coupled magnetic drive

Max. capacity	550 m ³ /h
Max head	160 m
Max pressure	16 bar (25 bar optional)
Max temperature	300°C (350°C optional)
Max viscosity	150 mPas
Max power	99 kW at 3000 rpm
Max torque	315 Nm

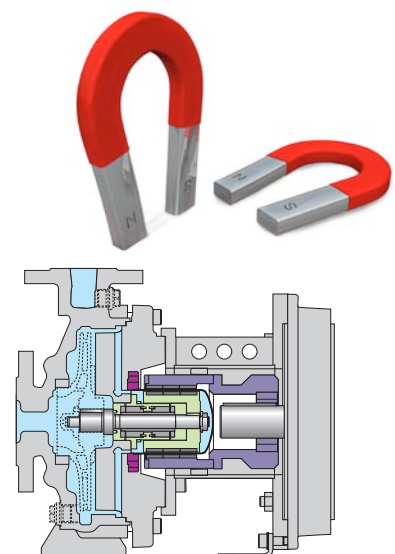

Close-coupled magnetic drive

Max. capacity	280 m ³ /h
Max head	140 m
Max pressure	16 bar (25 bar optional)
Max temperature	200°C
Max viscosity	150 mPas
Max power	45 kW at 3000 rpm
Max torque	168 Nm

Configuration options

In addition to the standardised horizontal end-suction centrifugal pumps the Combi family offers a number of configurations to suit nearly every application need.

Compact monobloc design

- Space-saving
- Stub shaft and lantern piece assembly
- IEC standard flanged motor

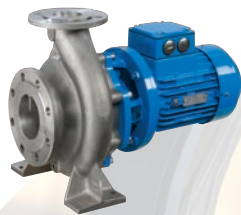

In-Line pump casing design

- Built-in circulation pumps with dry motor in a monobloc design
- The pumps can also be installed vertically on a foundation



- Specially shaped suction bends ensure low-noise operation and optimum NPSH
- Impeller mounted directly on extended motor shaft or mounted on stub shaft with standard IEC electric motor

Vertical configuration

- Space-saving
- Combi monobloc designs need only a V1 electric motor for vertical installation
- Other casing options provide for a base with or without an NPSH optimized, variable position suction bend.



Self-priming

- Combination shaft seal and vacuum pump of liquid ring type
- Shaft seal with integrated venturi/injector system
- Frame mounted IEC motors in horizontal or vertical configurations



Solids and gaseous content handling

- Combi pumps with vortex technology
- Recessed and specially formed impeller can handle gaseous content as well as solids
- Free hydraulic passage up to 100 mm
- Option for oil-quench, integrated venturi unit for self-priming capabilities or handling of higher gas content
- Available in horizontal, vertical or submerged configurations.



Submerged pump with dry motor

- Combi series of vertical, long-shafted sump pumps
- Closed, half-open and vortex impellers, depending on solids contents
- Specially developed range for applications in paint spraying installations with water curtains and cleaning installations with solvents

Black on white with Johnson Pump

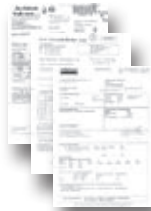

Material traceability EN 10204 certificates

- 2.1
- 2.2
- 3.1

Johnson Pump supplies you with a full range of documentation for our centrifugal pumps; everything from material traceability of the components, through quality assurance at our production plants to testing in-house of the final products.

Naturally, our pumps are CE safety certified as well as ATEX explosion protection certified.

Johnson Pump can also supply you with CAD dimensional drawings of our pumps to aid in your planning process.



ISO 9001 certificates for our production plants

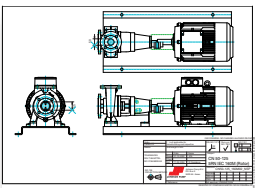

CAD dimensional drawings
for fitting into customer's pipe
workings

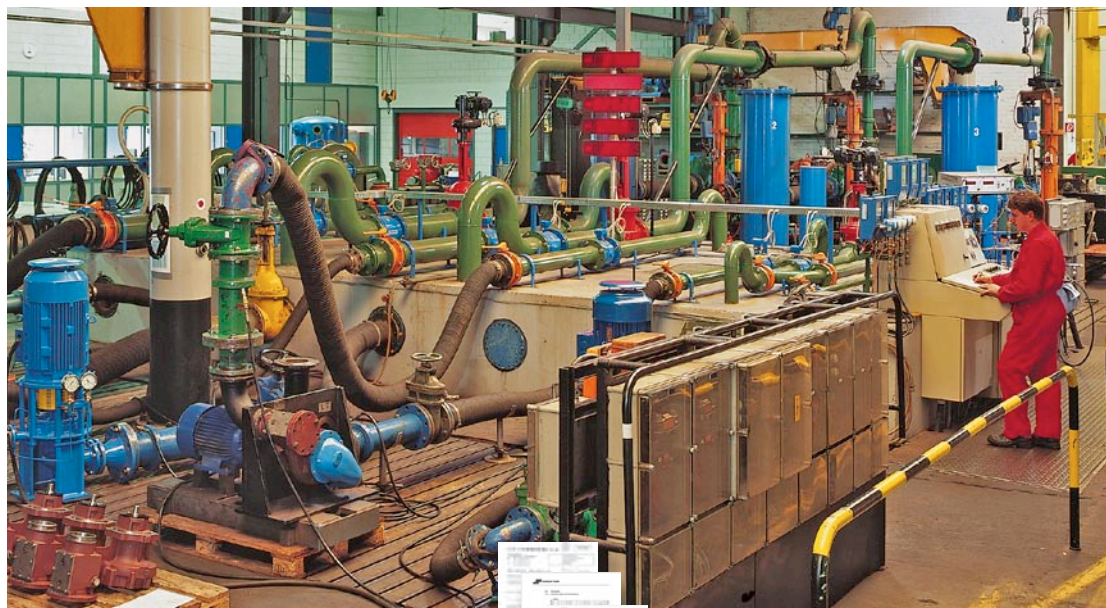

**QHP tests according to
ISO 9906 (ISO 2548)**

**Vibration tests according
to VDI 2056**

Noise level tests



Safety standards
EC declaration of conformity



Explosion protection
All of Johnson Pump's Combi centrifugal pumps can be ATEX certified when delivered in assembly with an ATEX certified electric motor.



Your local contact:

SPX Process Equipment Ltd.
Sales office Johnson Pump Brand

Meadow Brook Industrial Centre
Maxwell Way, Crawley
West Sussex RH10 9SA
United Kingdom

Tel. 01293-553495
Fax 01293-524635
johnson-pump.uk@processequipment.spx.com
www.johnson-pump.com/UK



SPX Process Equipment NL B.V.
Dr A.F. Philipsweg 51, P.O. Box 9
NL-9400 AA Assen, NETHERLANDS
Phone: +31 (0)592 37 67 67. Fax: +31 (0)592 37 67 60
E-Mail: jp-industry.nl@processequipment.spx.com

For more information about our worldwide locations, approvals, certifications, and local representatives, please visit www.johnson-pump.com and www.spxpe.com.

SPX Corporation reserves the right to incorporate our latest design and material changes without notice or obligation. Design features, materials of construction and dimensional data, as described in this bulletin, are provided for your information only and should not be relied upon unless confirmed in writing.