

CombiNorm

Horizontal centrifugal pump
according to EN 733 (DIN 24555)

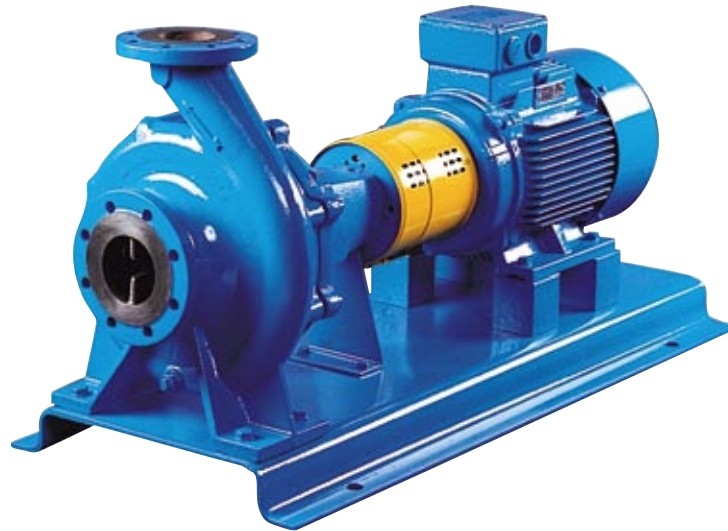

System characteristics

The CombiNorm is a part of the CombiSystem, a family of different pump types having a high interchangeability in parts.

The CombiNorm, designed to EN 733 (DIN 24255), offers a great variety in materials, shaft seals and bearing systems. Its modular design offers a high interchangeability between the variants. Hence, a CombiNorm is available to handle most pump duties.

Applications

The CombiNorm is suitable for handling low-viscosity, clean or slightly contaminated liquids, for virtually any applications.

Pump specifics

- Suitable for a wide span of duties
- Large hydraulic field of application
- High interchangeability in spare parts between different sizes, thus limiting spare parts stock levels
- Suitable for various liquids, thanks to the large number of standard and non-standard material options
- Simple maintenance thanks to the use of standard components and the Back-Pull-Out principle applied
- Flexible choice in bearings and shaft seal modules
- The entire pump family features only four bearing bracket groups

Technical data

Maximum capacity:	1500 m ³ /h
Maximum delivery head:	140 m
Maximum liquid temperature:	200 °C
Maximum speed:	3600 rpm
Maximum operating pressure:	10–16 bar (1000–1600 kPa) (depending on pump size/materials)

Materials

Pump casing	Cast iron	Nodular cast iron	Bronze
Stuffingbox cover	Cast iron	Nodular cast iron	Bronze
Impeller	Cast iron/Bronze		Bronze
Pump shaft	Alloy steel		Stainless steel
Shaft sleeve	Alloy steel/Bronze/Stainless steel		
Bearing bracket	Cast iron		

Other materials upon request

Performance data

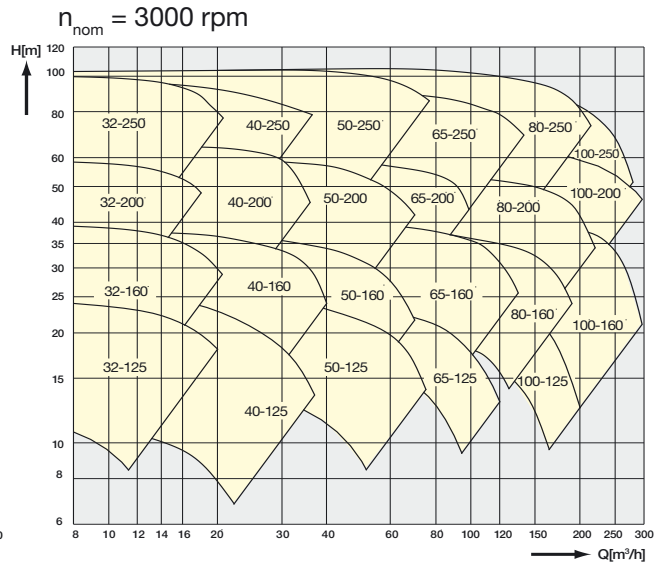
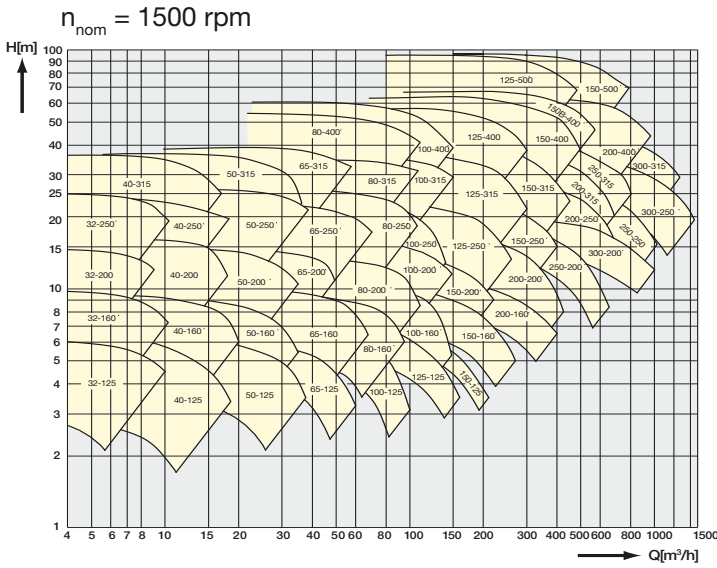

Dimensions

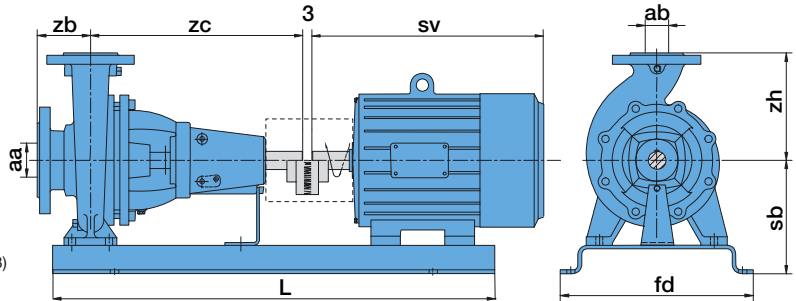

Flanges according to ISO 7005 PN 16 = EN 1092-2 (DIN 2532/DIN 2533)

CombiNorm	ISO 7005 PN16							
	aa	ab	zb	zc	sb	fd	zh	L
32-125	50	32	80	360	157-175	433-473	140	800-1000
32-160	50	32	80	360	177-195	433-473	160	800-1000
32-200	50	32	80	360	205-223	433-473	180	800-1000
32-250	50	32	100	360	243-260	473-545	225	1000-1250
40-125	65	40	80	360	157-195	433-473	140	800-1000
40-160	65	40	80	360	177-223	433-473	160	800-1000
40-200	65	40	100	360	205-223	433-473	180	800-1000
40-250	65	40	100	360	243-260	473-545	225	1000-1250
40-315	65	40	125	470	280	545	250	1250
50-125	65	50	100	360	177-223	433-473	160	800-1000
50-160	65	50	100	360	205-223	433-473	180	800-1000
50-200	65	50	100	360	205-290	433-678	200	800-1250
50-250	65	50	100	360	243-290	473-678	225	1000-1250
50-315	80	50	125	470	305	545	280	1250
65-125	80	65	100	360	205-240	433-545	180	800-1250
65-160	80	65	100	360	205-290	433-678	200	800-1250
65-200	80	65	100	360	243-290	473-678	225	1000-1250
65-250	80	65	100	470	280-325	545-678	250	1250-1600
65-315	80	65	125	470	315	678	280	1250
80-160	100	80	125	360	243-290	473-678	225	1000-1250
80-200	100	80	125	470	260-410	545-788	250	1250-1650
80-250	100	80	125	470	290-410	678-788	280	1250-1650
80-315	100	80	125	470	340-350	658-678	315	1250-1600
80-400	125	80	125	530	370-380	658-678	355	1250-1650
100-125	100	100	125	360	243-260	473-545	250	1000-1250
100-160	125	100	125	470	280-300	545-678	315	1250-1600
100-200	125	100	125	470	280-410	545-788	280	1250-1650
100-250	125	100	140	470	315-410	678-788	280	1250-1650
100-315	125	100	140	470	340-350	658-678	315	1250-1600
100-400	125	100	140	530	370-410	678-788	355	1250-1650

EC Motor	sv _{max}
71	235
80	270
90S	300
90L	325
100L	390
112M	425
132S	485
132M	520
160M	630
160L	670
180M	700
180L	735
200L	805
225S	835
225M	860
250M	960
280S	1065
280M	1115
315S	1235
315M	1260
315L	1340
315LX	1340
355S	1590

CombiNorm	ISO 7005 PN16							
	aa	ab	zb	zc	sb	fd	zh	L
125-125	125	125	140	360	288-305	473-545	300	1000-1250
125-250	150	125	140	470	340-350	658-678	355	1250-1600
125-315	150	125	140	530	370-410	678-788	355	1250-1650
125-400	150	125	140	530	405-445	678-788	400	1250-1650
125-500	200	125	200	680	530-560	850-1040	500	1600-2350
150-125	150	150	160	360	370	678	400	1250
150-160	150	150	160	470	340-380	678-788	315	1250-1650
150-200	150	150	160	470	340	678	315	1250
150-250	200*	150	160	530	370-410	678-788	400	1250-1650
150-315	200*	150	160	530	410	778	400	1650
150-400	200*	150	160	530	445	788	450	1650
150B-400	250	150	200	690	485-515	740-890	500	1600-2250
150-500	250	150	230	685	580-610	850-1040	550	1600-2350
200-160	200*	200*	200	470	370	678	400	1250
200-200	200*	200*	200	470	370-410	678-788	400	1250-1650
200-250	250	200	260	696	485	740	425	1600-1800
200-315	250	200	180	695	485-515	740-850	450	1600-2000
200-400	300	200	230	695	530-560	850-1040	550	1600-2350
250-200	250*	250*	200	530	445	788	450	1650
250-250	300	250	260	716	530-560	850	550	1600-2000
250-315	300	250	230	700	505-535	850-890	500	1600-2250
300-200	300*	300*	250	530	580	788	600	1650
300-250	300	300	250	720	580-610	850	550	1600-2000
300-315	300	300	230	720	580-610	850-890	550	1600-2350

sv, L: depending on motor-frame size
 sb, fd, L: depends of choice of standard or spacer coupling
 *: Flanges aa & ab according ISO 7005 PN 10



JOHNSON PUMP

An SPX Process Equipment Operation

Johnson Pump (Australia) Pty. Ltd