



JOHNSON PUMP
AN SPX BRAND

CombiSump

Vertical long shaft sump pump, according to
ISO 2858, EN 733 (DIN 24255), API 610



CE 

SPX[®]

CombiSump

CombiSump is the sump pump solution for thin liquids. The pump is part of Johnson Pump's Combi-system, a modular programme of single stage centrifugal pumps with a high degree of interchangeability of parts between the different pump constructions.



The CombiSump is a range of centrifugal sump pumps, with the pump casing submerged into the liquid and a dry motor construction.

The hydraulic parts of these submersible pumps make use of the pump casings and impellers of the CombiPro, CombiChem or CombiNorm pumps, their respective hydraulic fields meeting API 610, ISO 2858 (EN 22858/DIN 24256) and EN 733 (DIN 24255).

The pump is driven by a customer specified or standard IEC flange electric motor 'V1(IM3011)' placed on a lantern piece mounted on the base plate. The power is transmitted through a flexible coupling and a long shaft.

The pump casings' pressure flange is connected to a discharge connection on the base plate.

Technical data

Max. capacity	1500 m ³ /h
Max. head	160 m
Max. temperature	160°C
Max. speed	3600 rpm
Design pressure	up to 16 (35) bar



From know-how to finding solutions

General industry

CombiSump pumps can be used for all kinds of sump duties. Another known application is pumping cooling water when river or lake water is used for chilled cooling water processes.



Petrochemical industry

CombiSump pumps are often used for draining waste water collecting bassins. Typical process duties are e.g. drain pump or hydrocarbon condensate.



Off Shore

In Off Shore industries CombiSump pumps are used for several duties where it is desirable to have the electric motor at distance of the pumped liquid.



Features and *benefits*

Electric motor

- mounted on a steel made motor support lantern piece
- accurate alignment by means of adjusting bolts
- *customer specified or standard IEC flange motor 'V1 (IM 3011)'*

Coupling

- standard fitted with flexible coupling
- *optionally available with membrane coupling or non-sparking coupling*
- *coupling guard to prevent entrance to the rotating parts*

Delivery connection

- placed on the baseplate
- flanges according to ISO 7005 PN 16, PN 20, PN 50
- flanges according to ANSI B16.5 150 lbs, 300 lbs
- *horizontal or vertical position possible*

Baseplate

- standard version is a rectangular plate
- round flange shaped plate is optional (API 610)
- *can be adapted to the size of the pit according to customer specifications*
- *lifting lugs for easy maintenance*
- *provided with earthing boss*

Column pipe and pump shaft

- situated below the baseplate
- consisting of one or more parts
- connects the pump casing with the baseplate
- *column pipe protects the shaft*
- *supports the eventual intermediate bearings*
- *sump depth according to customer specification*
- *design consists of 4 shaft groups*

Pump casing/impeller

- impeller design for low NPSH values
- available impeller types: closed impeller, half open impeller with wear plate and vortex impeller
- anti-rotation device at impeller inlet
- suction strainer
- *optimised hydraulic performance*
- *suitable for a wide range of liquids*
- *impeller protected from clogging*



Benefits

- Available in several materials
- High pump efficiency
- Suited for a wide span of duties
- Easy maintenance
- Compact, space saving construction
- Low maintenance cost
- Designed to meet specific lengths and application requirements
- Base plate designed to meet existing support arrangements

Bearings

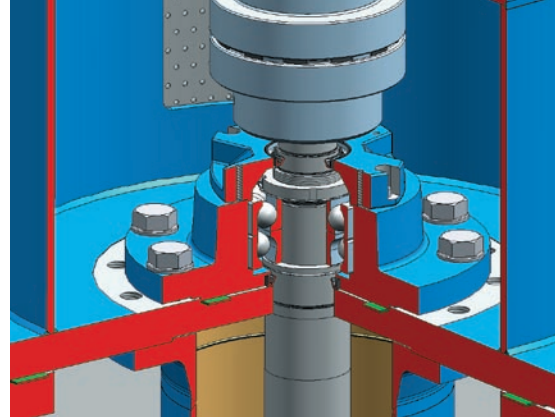
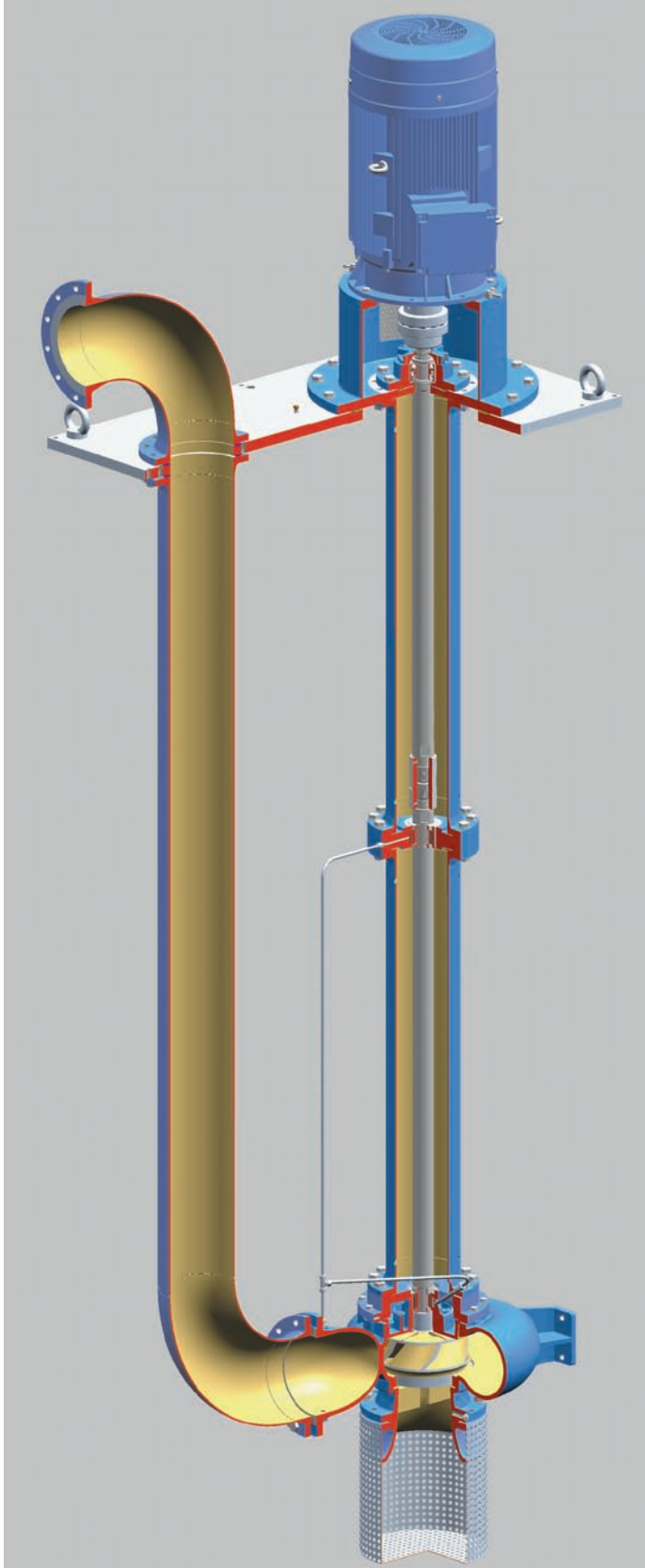

Ball bearing construction

- double-row angular-contact ball bearing for axial loads on the pump shaft.
- grease lubricated

The 'dry' part of the pump is provided with a double-row angular-contact ball bearing (two single row angular-contact ball bearings for bearing group 4) for bearing the axial loads of the pump shaft.

The shaft of the 'wet' part of the pump is provided with liquid lubricated slide bearings. The liquid is supplied directly from the discharge nozzle of the pump casing.

Slide bearings

- pump shaft provided with slide bearings
- number of slide bearings depending on the length of the pump shaft
- *ceramic bearings, liquid lubricated*

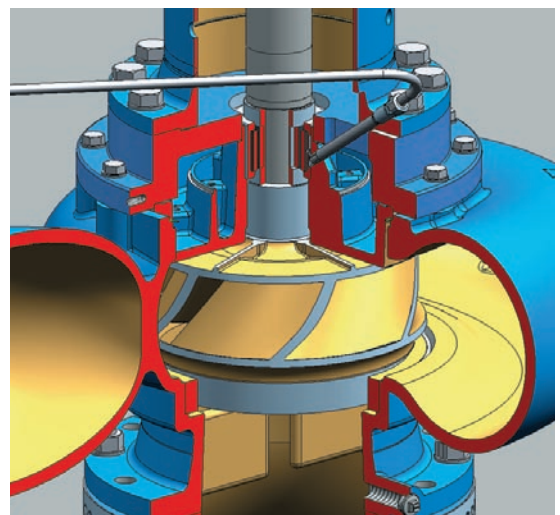
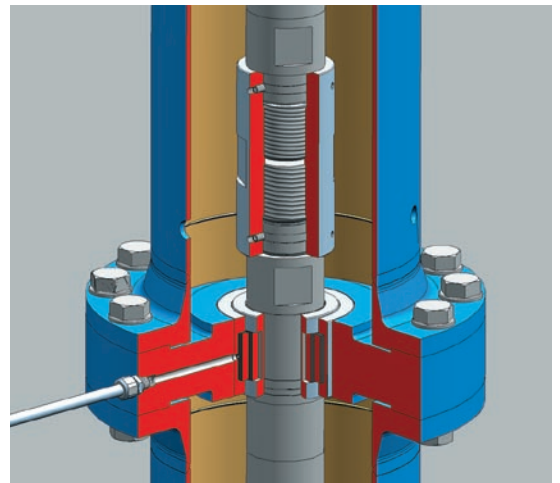

Shaft sealing

Standard the baseplate is provided with an oil baffle for sealing the shaft passage. For pressure tank applications a mechanical seal or gland packing is optionally available. On request a hermetically sealed shaft sealing solution can be supplied by mounting a mag drive coupling.

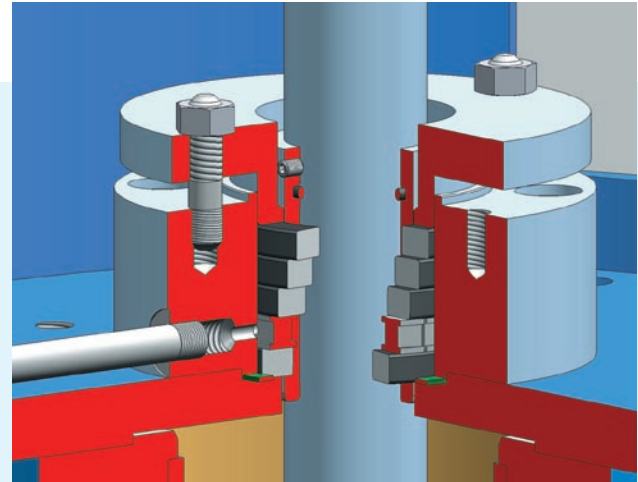
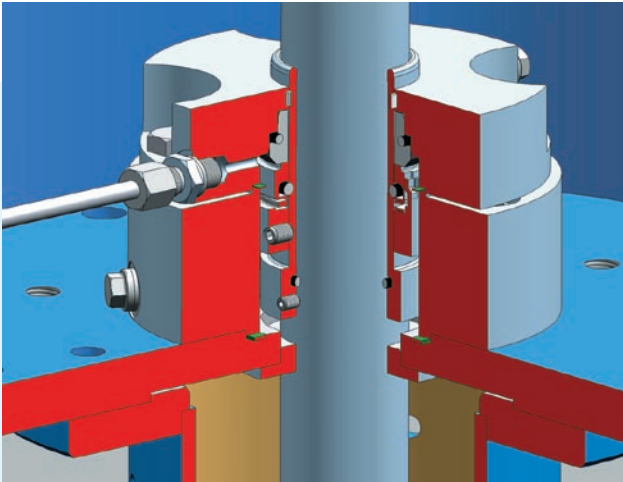

Materials

Parts	Standard available materials		
Pump casing	stainless steel	cast steel	cast iron
Impeller	stainless steel	bronze	cast iron
Shaft	stainless steel	bearing group 4: steel	
Stand pipe	stainless steel	steel	
Delivery pipe	stainless steel	steel	
Slide bearings	SiC-SiC		

Alternative materials according to customer specifications.

Impeller types

The standard impeller is a closed impeller, but for contaminated liquids, containing fibres, a half open impeller or a vortex impeller is available on request.

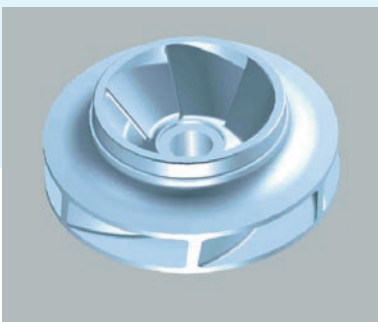

Closed impeller

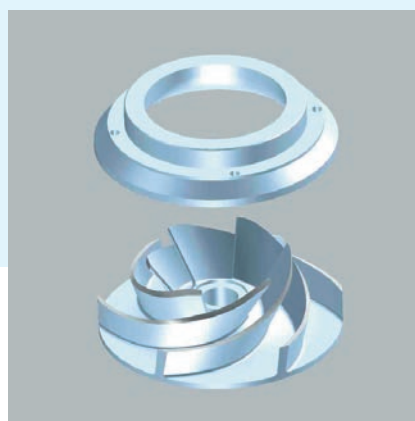

Half open impeller

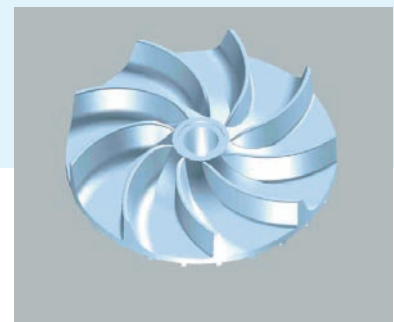

Vortex impeller

Performance overview

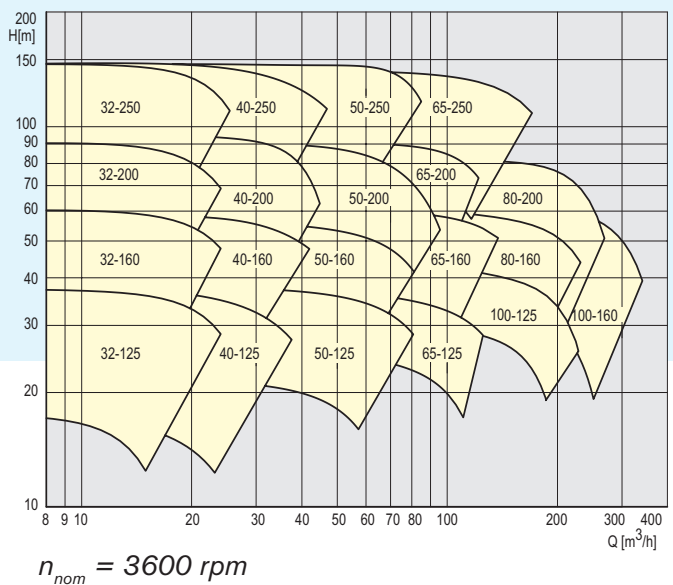
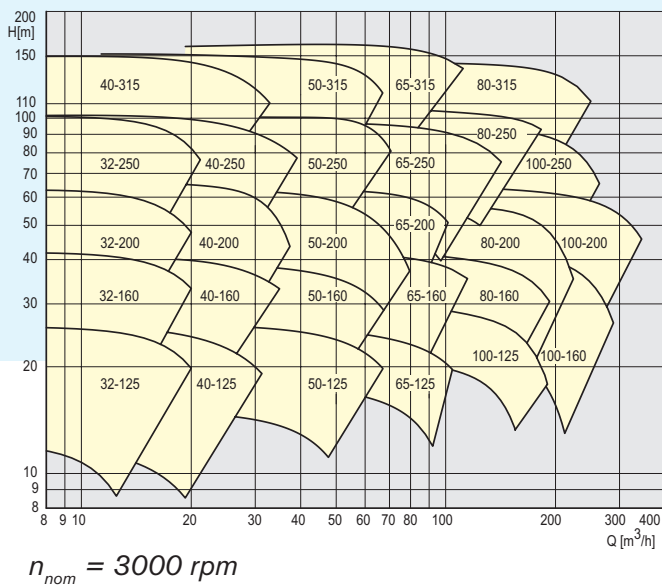
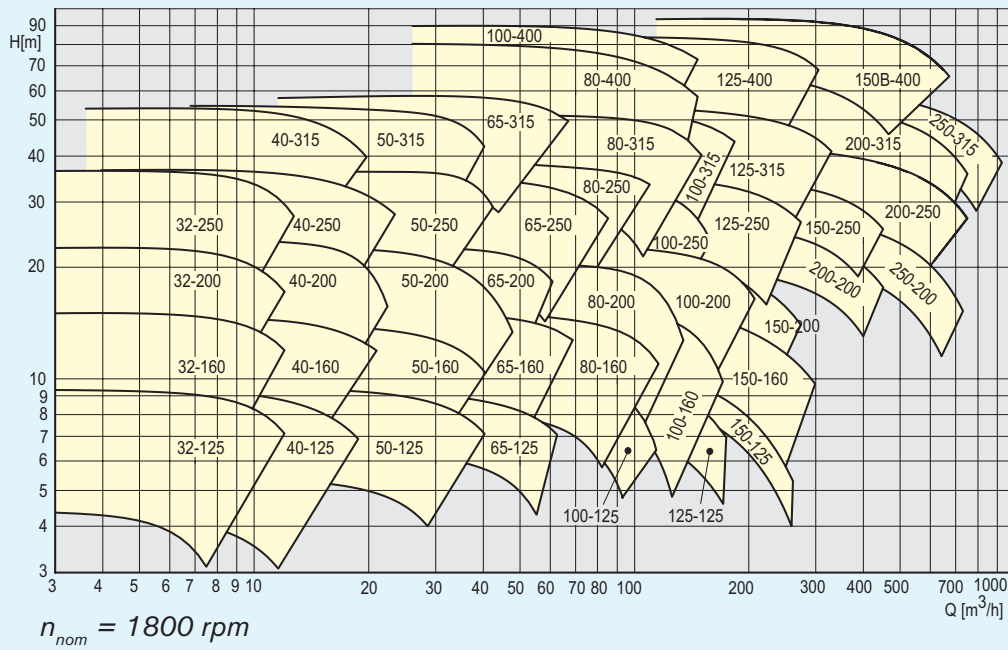
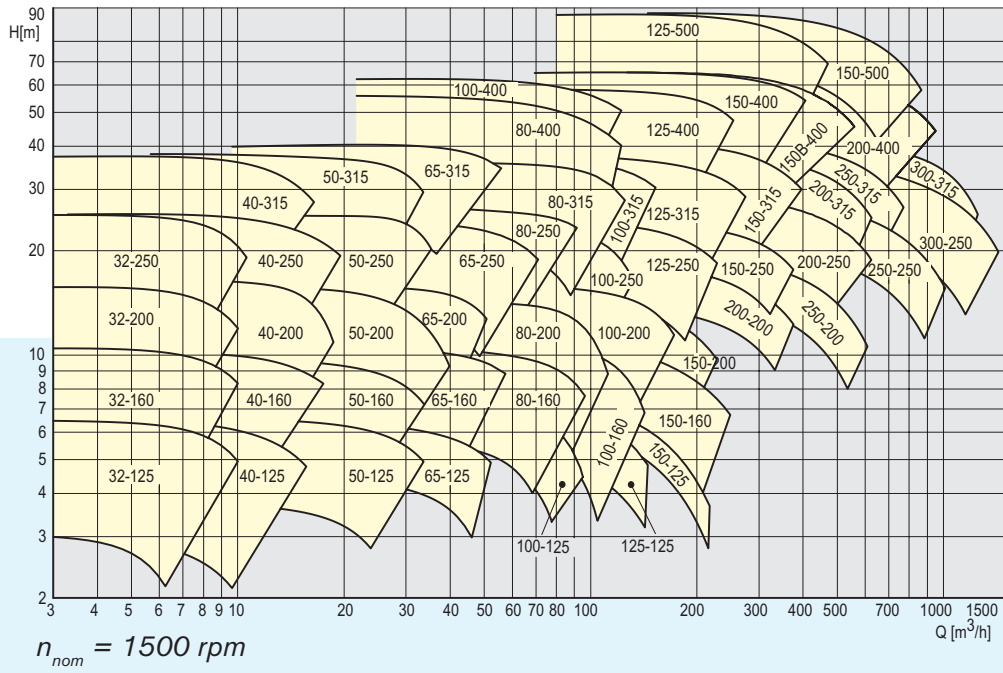



Your local contact:

SPX Process Equipment Ltd.
Sales office Johnson Pump Brand

Meadow Brook Industrial Centre
Maxwell Way, Crawley
West Sussex RH10 9SA
United Kingdom

Tel. 01293-553495
Fax 01293-524635
johnson-pump.uk@processequipment.spx.com
www.johnson-pump.com/UK



SPX Process Equipment NL B.V.
Dr A.F. Philipsweg 51, P.O. Box 9
NL-9400 AA Assen, NETHERLANDS
Phone: +31 (0)592 37 67 67. Fax: +31 (0)592 37 67 60
E-Mail: jp-industry.nl@processequipment.spx.com

For more information about our worldwide locations, approvals, certifications, and local representatives, please visit www.johnson-pump.com and www.spxpe.com.

SPX Corporation reserves the right to incorporate our latest design and material changes without notice or obligation. Design features, materials of construction and dimensional data, as described in this bulletin, are provided for your information only and should not be relied upon unless confirmed in writing.