



JOHNSON PUMP GROUP
AN SPX BRAND

TopWing Bi-Wing Rotary Lobe Pumps



SPX®

TopWing – The next generation of rotary lobe pumps

Clean, heavy duty, efficient. Features that SPX Process Equipment aimed at when we took the challenge to develop the next generation of rotary lobe pumps. And the result is TopWing.

Thanks to the innovative design of the Johnson Pump brand TopWing, SPX Process Equipment offers a pump with optimal efficiency.

If you need a tough pump, you've got it. Or if you need a reliable pump, you've got it. Without compromising hygiene. Shear sensitive liquids will be handled with less damage due to the Bi-wing design with close clearances.

The heavy duty design coupled with easier maintenance are features you will find of great benefit.

In short, TopWing gives better performance at lower costs.

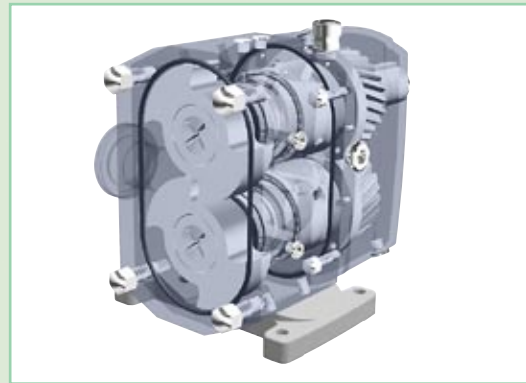

Typical characteristics

- Front loading seals
- Complete pump in stainless steel
- Duplex stainless steel shafts and rotors
- Smooth flow
- Superior sanitary design
- Heavy duty operation
- Self-draining
- Bi-wing rotor
- Special gear case seals to minimize water/cleaning solution intrusion
- High efficiency
- Easily serviced and maintained
- Handles high and low viscosity products

TopWing – The intelligent answer in rotary lobe pumps



Technical know-how and market knowledge are the driving forces for SPX Process Equipment in designing and manufacturing the next generation of Johnson Pump brand rotary lobe pumps, the TopWing.

The hygienic design combined with a gentler product handling makes TopWing the ideal solution for sensitive liquids. The ability to pump liquids of varying viscosities and temperatures are other benefits.

The shape of the rotor promotes a smooth flow with a high volumetric efficiency. There are fewer pockets where bacteria can hide. Features that make the pump easy to clean – both by CIP and by SIP. The complete pump is made of stainless steel.

With less agitation and shear TopWing can handle delicate liquids containing both soft and hard particles without product degradation.

This new design meets all the demands for high product quality. It stands up well to the requirements from different markets for various applications. Still giving a smooth even flow, reliable operation without compromising hygiene.



Features and Benefits

Sanitary design – fewer cavities where bacteria can hide

- Self-draining rotorcase in vertical position
- Self-draining mechanical seals assembled inside the rotorcase
- 316 L Stainless steel body and cover
- Smooth standard surface finish of 30 R_a for both rotorcase and frontcover (electro-polish finish 20 R_a on request)
- Easy to clean – CIP, SIP or manually.

Easily maintained

- Change of shaft seal without disassembling the rotorcase
- Heavy duty bearing design -pre-loaded taper roller bearings without shimming

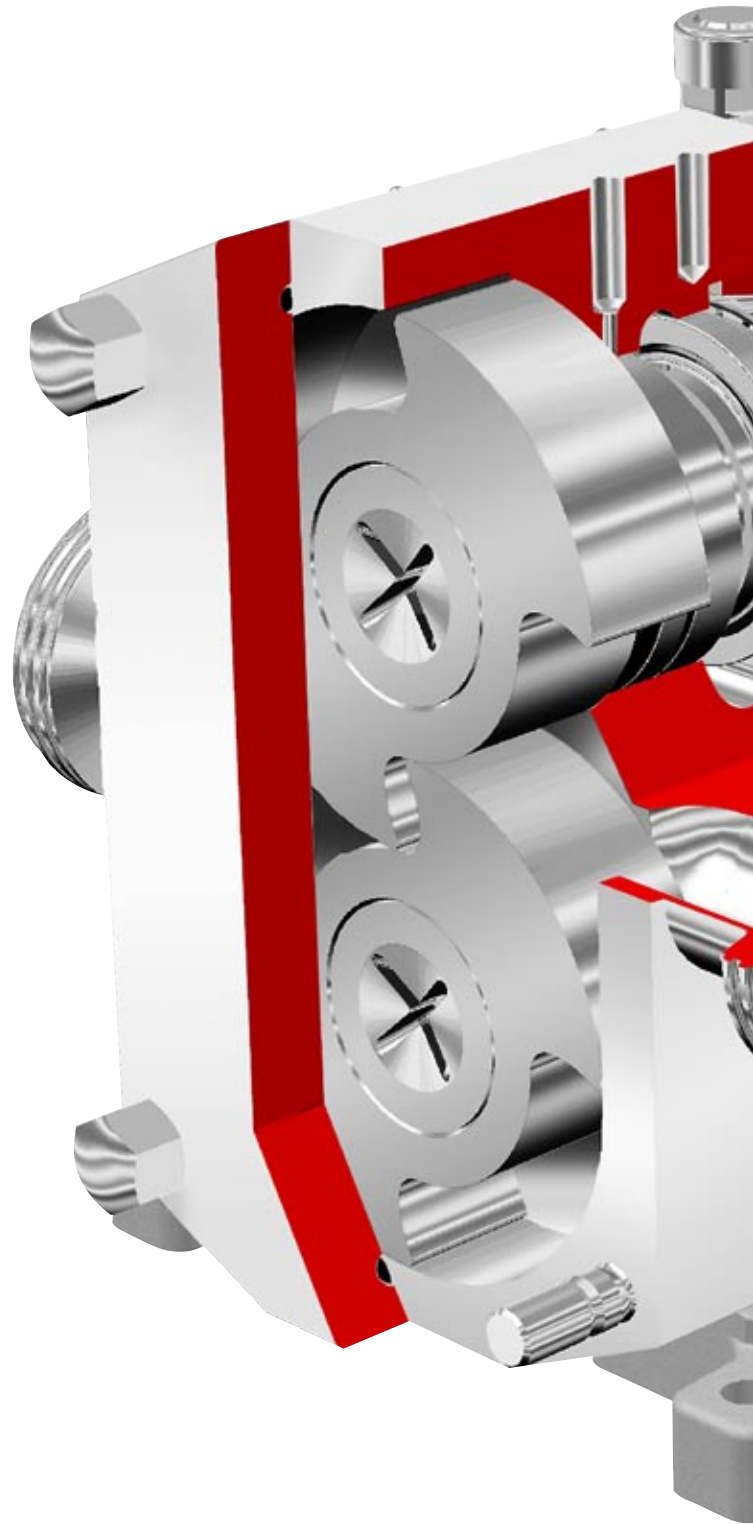
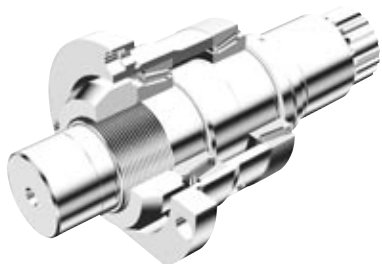

Designed for extreme external environments

- Water resistant gear case with special seals to minimize cleaning solutions/water into bearings
- Complete pump manufactured in stainless steel, including the endcover – no corrosion, no painting

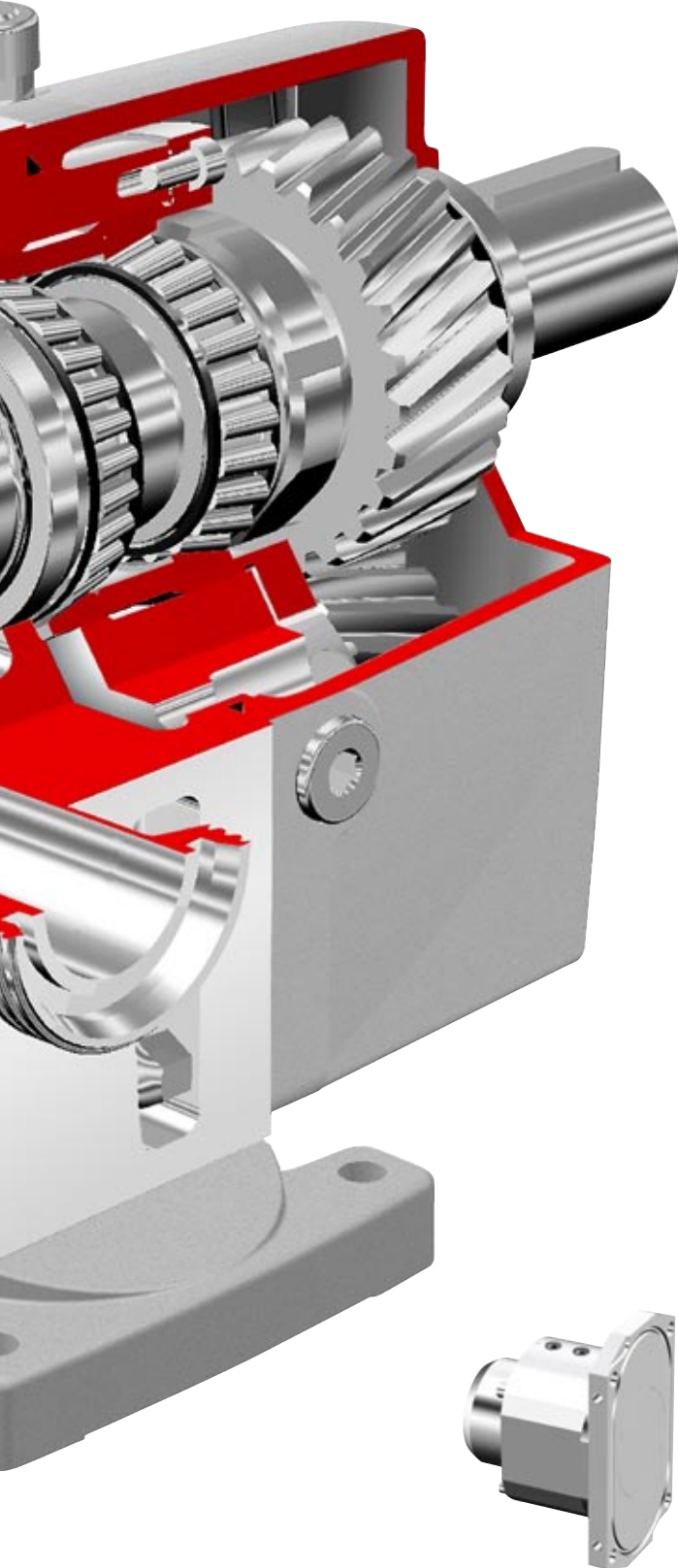

Gentle product handling – high performance

- Bi-wing rotors – less backslip and possibility to handle soft particles thanks to the rotor shape
- One piece pump and gear case body – minimizes shaft and bearing alignment during assembly and repair.
- Small clearances – less backslip and gentler treatment of shear sensitive liquids
- Smooth flow, low pulsation

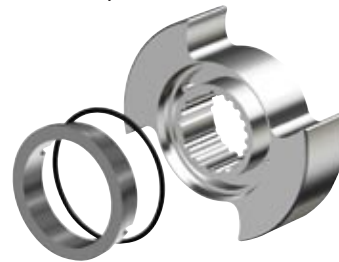

Trouble-free operation

- Designed for harsh environments
- Rotors, shaft and retainer of Duplex stainless steel – stronger assembly, less shaft deflection, less wear
- Heavy-duty construction – larger shaft diameter and Duplex stainless steel standard
- Mechanical seal assembled inside the rotorcase – better seal lubrication
- Up-graded material in mechanical seal and newly invented triple wave spring

Options

- Different seals; single mechanical, quenched, double flushed, O-ring
- Safety relief valves; manual adjustable spring loaded or pneumatic. Easy to clean pneumatic option can also be used as CIP-valve with process controls
- Rectangular inlets – lower NPSHr, ability to handle high viscosity liquids
- Pre-heating/cooling devices in frontcover and/or at the seals

Pharmaceutical options

- 20 R_a Electro-polish interior
- Complete documentation package

Materials of key components

When designing the high quality TopWing pump, we focused on reducing the LCC (Life Cycle Cost). This means that not only the construction itself is up-graded but also the pump materials.

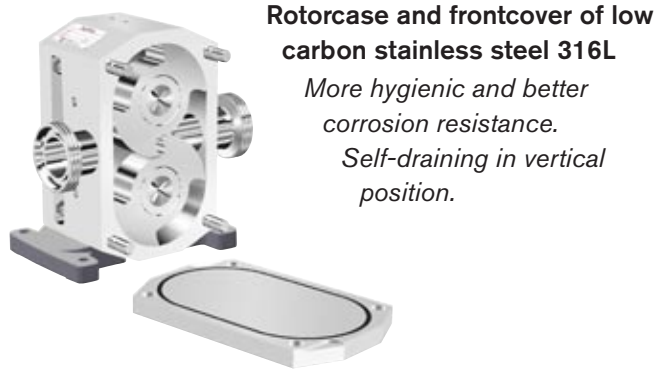

Rotorcase and frontcover of low carbon stainless steel 316L
*More hygienic and better corrosion resistance.
 Self-draining in vertical position.*

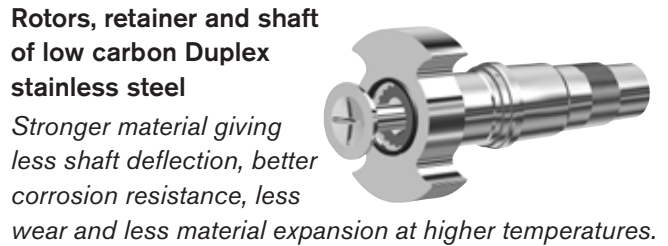

Rotors, retainer and shaft of low carbon Duplex stainless steel
Stronger material giving less shaft deflection, better corrosion resistance, less wear and less material expansion at higher temperatures.

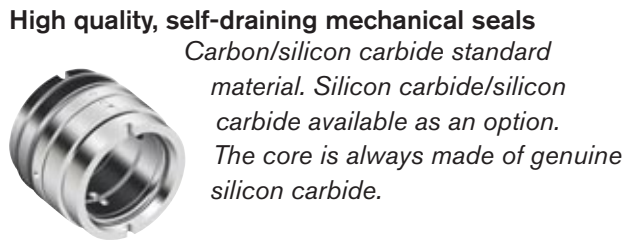

High quality, self-draining mechanical seals
*Carbon/silicon carbide standard material. Silicon carbide/silicon carbide available as an option.
 The core is always made of genuine silicon carbide.*



Gear case cover constructed in stainless steel
Corrosion resistant, no painting of the pump.

Technical data

The TopWing series consists of eight pumps with connection sizes from 1 inch to 4 inches with capacities up to 680 GPM and maximum working pressure up to 220 psi.

Pump type	Displacement (US Gal/Rev)	Maximum capacity (GPM)	Port size (Inches)	Maximum pressure (psi)	Maximum speed (rpm)	Maximum torque (in.-lbs.)
TW1/0041	0.011	15	1	220	1400	360
TW1/0082	0.022	31	1	100	1400	360
TW2/0171	0.045	54	1.5	220	1200	3540
TW2/0343	0.091	109	2	100	1200	3540
TW3/0537	0.142	142	2	220	1000	7080
TW3/1100	0.291	291	3	100	1000	7080
TW4/1629	0.43	344	3	220	800	17,700
TW4/3257	0.86	688	4	100	800	17,700

Dimensions

Horizontal mounting

Broken line shaft shows position for bottom drive version

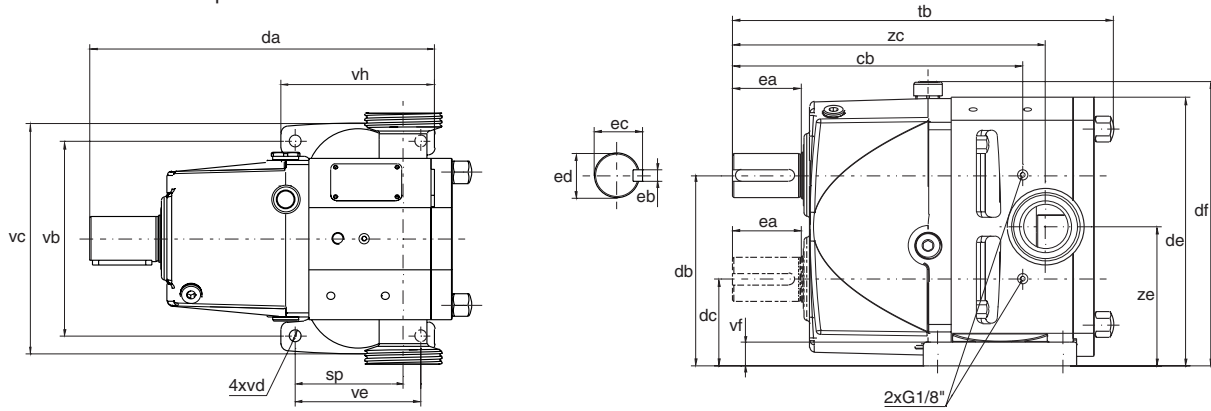

Vertical mounting

Broken line shaft shows position for left drive version seen from the frontcover

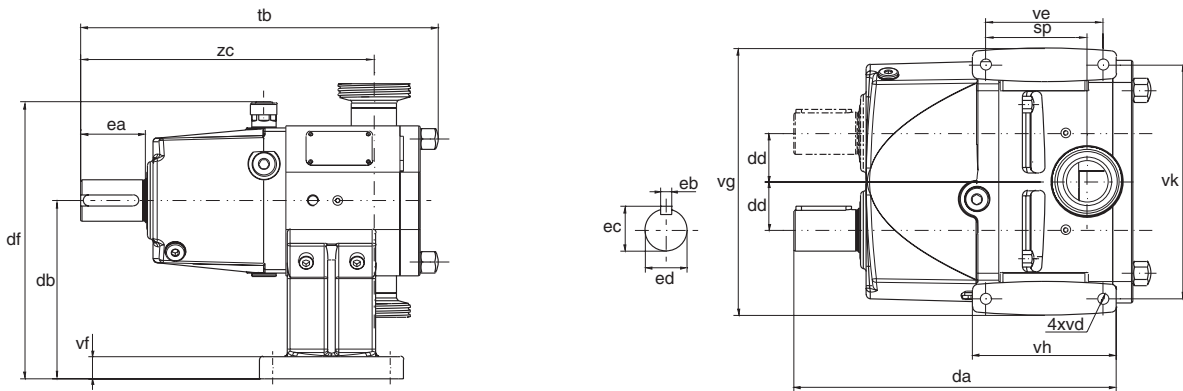

Dimensions in inches - * shaft dimensions in mm

Pump type	cb	da	db	dc	dd	de	df	ea*	eb*	ec*	ed*	sp	tb	vb	vc	vd	ve	vf	vg	vh	vk	zc	ze
TW1/0041	7	8.4	4.47	2.2	1.14	6.32	6.97	35	6	21.5	19	2.58	9.5	4.3	5.31	0.4	2.9	0.6	6.9	3.7	5.9	7.6	3.33
TW1/0082	7	8.4	4.47	2.2	1.14	6.32	6.97	35	6	21.5	19	3.17	10.1	4.3	5.31	0.4	2.9	0.6	6.9	3.7	5.9	8.2	3.33
TW2/0171	9.6	11.5	6.38	2.9	1.73	8.98	9.53	58	10	41	38	3.6	13	6.5	7.68	0.4	4.2	0.8	9.5	5.1	8.4	10	4.65
TW2/0343	9.6	11.5	6.38	2.9	1.73	8.98	9.53	58	10	41	38	4.57	14	6.5	7.68	0.4	4.2	0.8	9.5	5.1	8.4	11	4.65
TW3/0537	12	14.6	8.48	3.9	2.3	12	11.6	82	14	51.5	48	4.65	16	8.4	10	0.6	5.3	1	13	6.7	11	13	6.18
TW3/1100	12	14.6	8.48	3.9	2.3	12	11.6	82	14	51.5	48	5.83	18	8.4	10	0.6	5.3	1	13	6.7	11	14	6.18
TW4/1629	17	19.6	11.7	5.3	3.19	16.7	17	140	20	74.5	70	5.45	22	12	14.8	0.7	6.3	1.2	18	7.9	16	18	8.5
TW4/3257	17	19.6	11.7	5.3	3.19	16.7	17	140	20	74.5	70	7.19	25	12	14.8	0.7	6.3	1.2	18	7.9	16	20	8.5

Connections

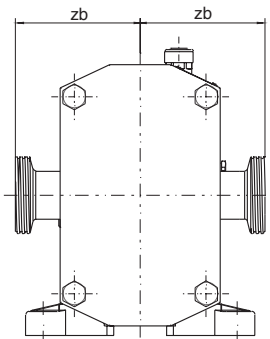

Dimensions in inches

Pump type	1-zb	2-zb
TW1/0041	3.35	4.61
TW1/0082	3.35	4.61
TW2/0171	4.21	5.47
TW2/0343	4.21	5.47
TW3/0537	5.16	6.42
TW3/1100	5.35	6.61
TW4/1629	7.01	8.27
TW4/3257	7.17	8.35

1-zb = All thread connections (DIN, ISO, Triclamp)
2-zb = All flanges DIN (PN16) and ANSI (class 150)

SPX[®]
PROCESS EQUIPMENT

Your local contact:



SPX Process Equipment
611 Sugar Creek Road
Delavan, WI 53115
Phone: (262) 728-1900, Toll Free: (800) 252-5200, Fax: (262) 728-4904
E-mail: spxpe@spx.com

For more information about our worldwide locations, approvals, certifications, and local representatives, please visit www.johnson-pump.com and www.spxft.com.

SPX Corporation reserves the right to incorporate our latest design and material changes without notice or obligation. Design features, materials of construction and dimensional data, as described in this bulletin, are provided for your information only and should not be relied upon unless confirmed in writing. Certified drawings are available upon request.