

# *OptiFlo*

*Air Operated Diaphragm Pumps*



# Reduced pulsation



*Johnson Pump has solved the problems inherent in conventional AODD pumps. How? With revolutionary new technology that we have incorporated into our latest innovation – OptiFlo.*

# on – efficient flow

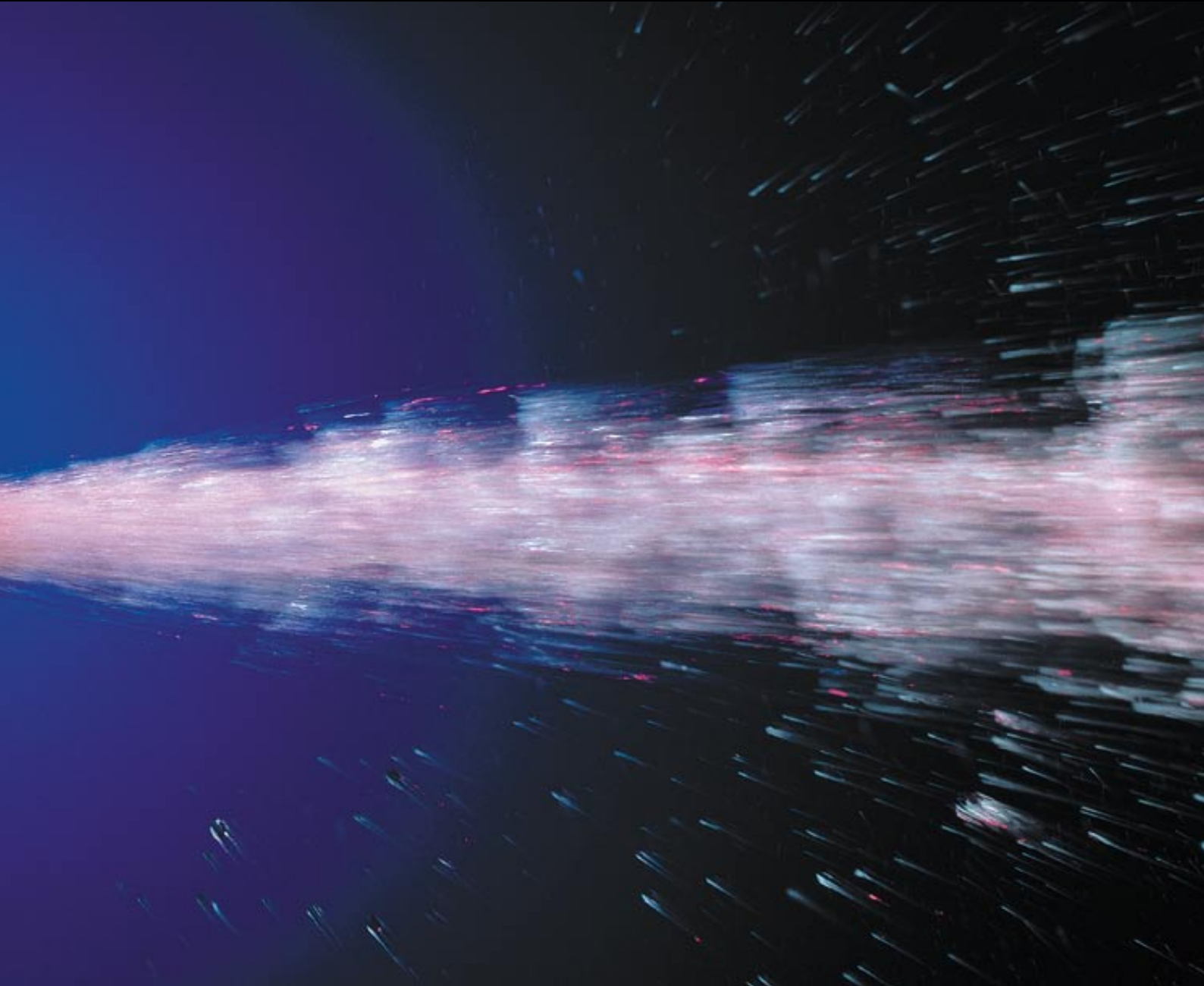

---

## The five steps to our unique AODD solution

---

**Step 1:** Develop a new non-stalling air motor that works with all types of air – dry, moist, dirty or oily – without icing problems.

**Step 2:** Invent a new type of air valve – an ingenious pneumatic device that switches the distribution of air between the air chambers in a fraction of a second.

**Step 3:** Design a central flow path, giving less hydraulic loss and reduced air consumption.

**Step 4:** Develop a flexible diaphragm suspension, which eliminates “dead ends” and gives lower pulsation.

**Step 5:** Replace the usual noisy ball valves with flap valves, thereby reducing pulsation and improving the suction capability.

These five steps together create an engineering high tech OptiFlo! The challenger that improves and

# The OptiFlo way

**Central flow in OptiFlo**

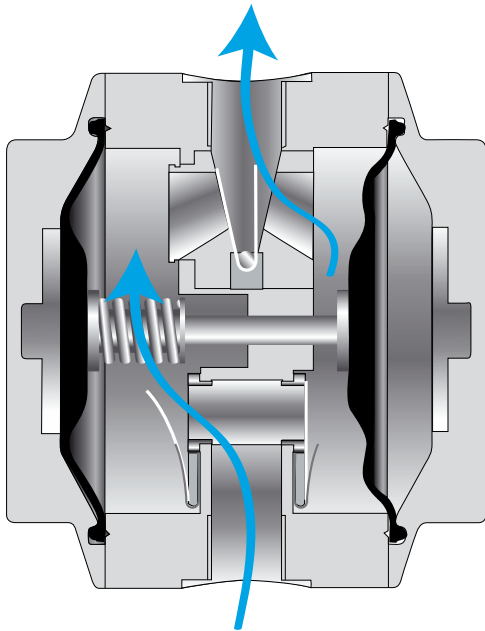

**Peripheral flow in a conventional AODD pump**

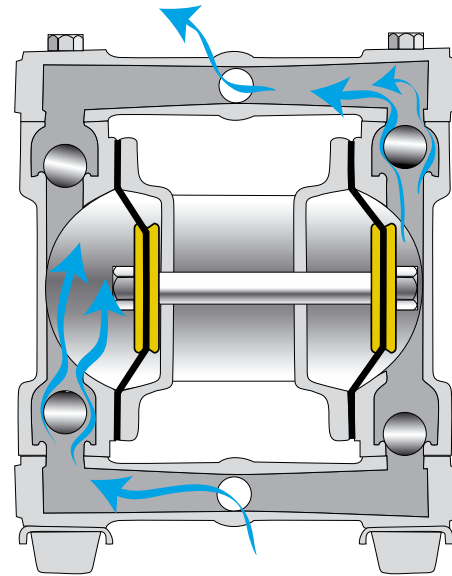

## New solutions to old problems

AODD pumps haven't really changed much over the years. The basic design has remained the same. Until now! With OptiFlo, Johnson Pump can introduce a new way of thinking.

Johnson Pump has invested a lot of time in product development, searching for innovative solutions to existing problems.

Radical new concepts, much imagination and several patented inventions were needed. The result?

A compact and robust AODD pump with lower pulsation that works silently and gives better performance at a lower life cycle cost.

Lower pulsation gives a strong, even flow, and less vibration. This results in better performance at a lower cost.	Extremely compact design with centre flow - perfect for built in applications.
Central flow path minimises energy losses and reduces air consumption.	Pneumatic controlled Airmotor with self-sealing port elements eliminates any demand for cleaned air supply.
Flap valves are silent – no rattle – and allow the pump to operate in any mounting position.	On-line design – instant change of all wear parts on site.
Simple design makes servicing, by unskilled personnel, easier and more cost effective and reduces down time.	The FDS (Flexible Diaphragm Suspension) technology minimizes the stress on the diaphragms and hence increases the service life substantially.

# The OptiFlo challenge

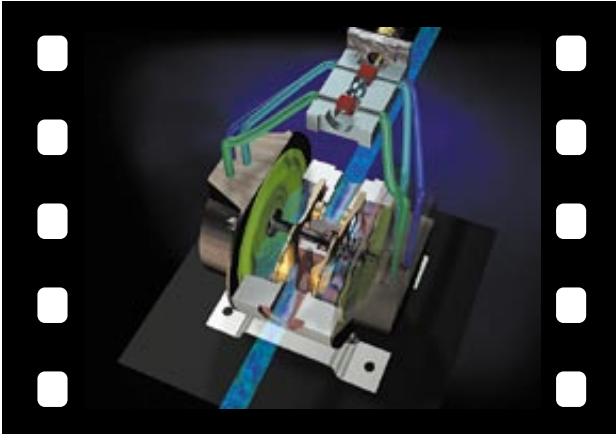

A closer look inside OptiFlo clearly shows why, in every respect, OptiFlo is a completely breakthrough in AODD pump design. A design that is simple and compact, yet full of new patents and smart solutions.

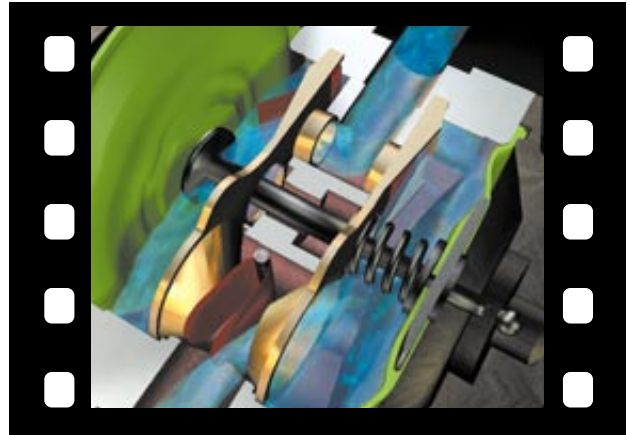

Instead of forcing the fluid round four transverse directions, OptiFlo pumps it straight through on a central flow path. This reduces hydraulic losses and gives a stronger, even flow. The principle is simple – straightforward is best!

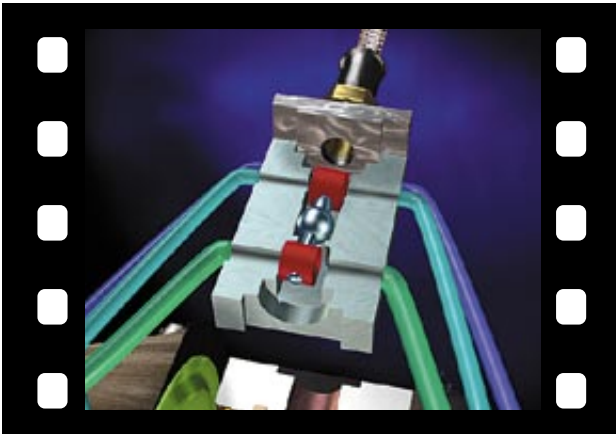

The new self-cleaning and non-stalling pneumatic air motor works with any kind of air — dry or moist, dirty or oily.

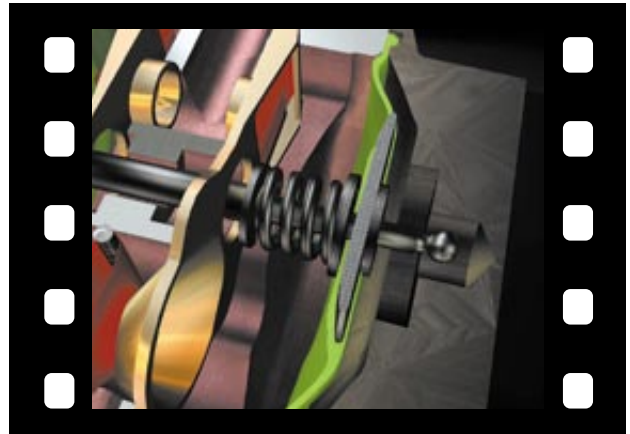

The patented Flexible Diaphragm Suspension (FDS technology) is one of the keys to the low pulsation of OptiFlo. The diaphragms are not fixed to the shaft, thus creating an overlapping motion and a low-pulsating, even flow.

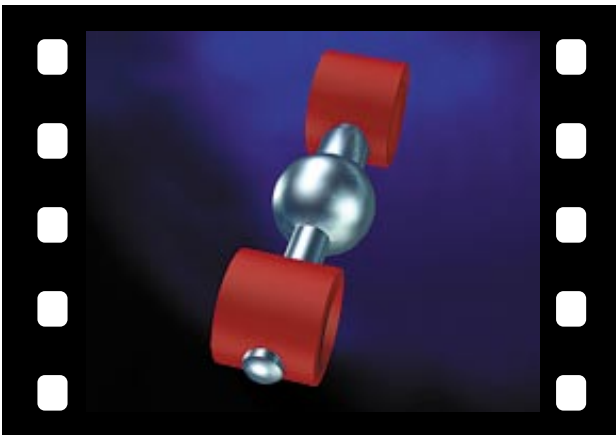

The Frictionless Pivoting Valve (FPV technology) is an ingenious innovation. The design facilitates the very fast switches in direction of air distribution that are needed to keep the diaphragms in overlapping motion. A new patent and a breakthrough for AODD pumps.

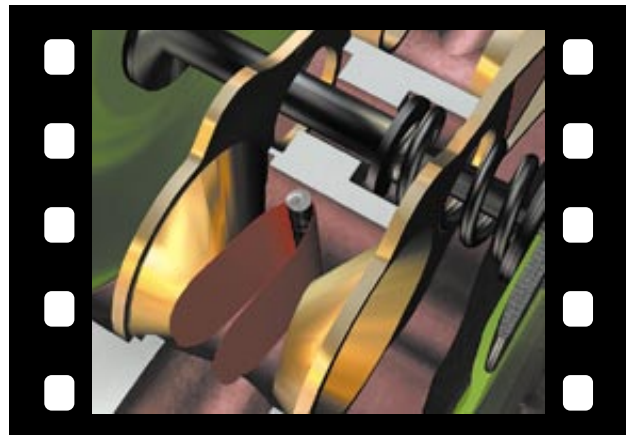

Flap valves work in all positions, and OptiFlo can therefore be mounted upside down if necessary. Flap valves are quiet – unlike the traditional ball valves with their noisy rattles. They also handle solid particles better.

# Can be opened in next to no time

A complete air motor with no mechanical link to the pump unit. It can be inspected and serviced without dismantling the wet parts. With the silencer replaced by a hose, OptiFlo becomes a simple submersible pump.

The heart of the air motor, the FPV (Frictionless Pivoting Valve), is easily accessible.

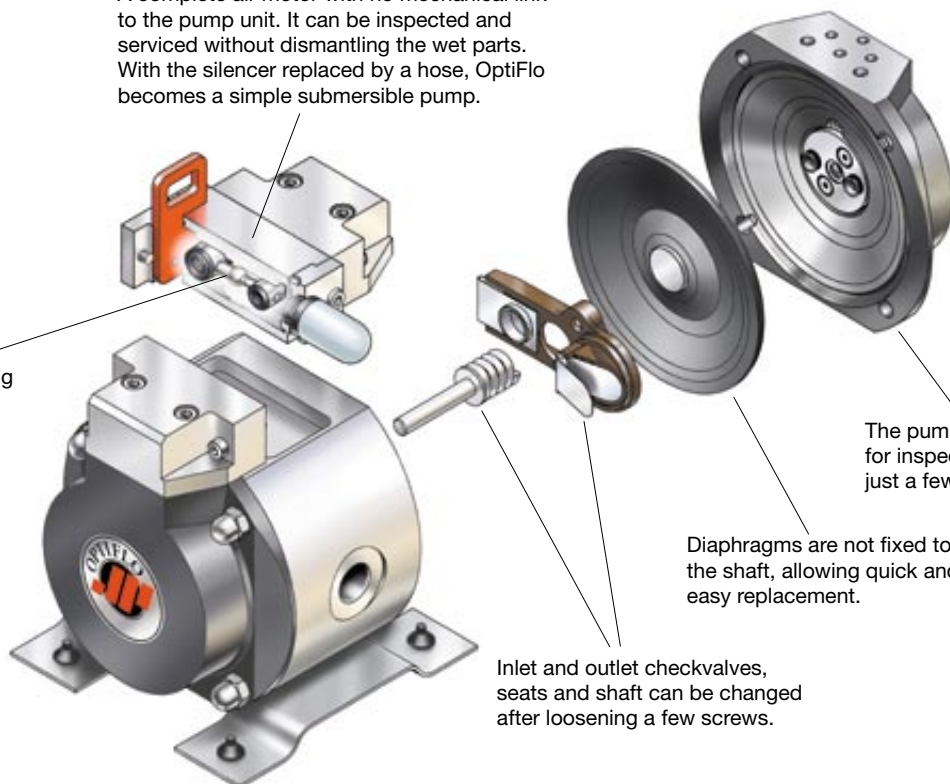

The pump can be opened for inspection or service in just a few minutes.

Diaphragms are not fixed to the shaft, allowing quick and easy replacement.

Inlet and outlet checkvalves, seats and shaft can be changed after loosening a few screws.

OptiFlo is very easy to install and maintain thanks to its compact and well thought-out design. With a few turns of the wrist, you can quickly open the pump and access its vital parts. Service and maintenance of traditional AODD pumps are costly and time-consuming. But with OptiFlo, that's a thing of the past. And because OptiFlo works in any position, there are no restrictions on how you mount it.

## Works in closed systems

Thanks to the central flow principle and the fact that the diaphragms are not fixed to the shaft, they do not come under excessive stress from the system pressure if the air supply fails. Thus, OptiFlo can be integrated into closed pumping systems.

## APPLICATIONS

OptiFlo will give you better performance at lower cost.  
Here are some examples of where and when OptiFlo can be used.

INDUSTRY	APPLICATION/PRODUCT	INDUSTRY	APPLICATION/PRODUCT
Construction/ General Industry	Draining of tanks and sumps, sampling, fuels	Pharmaceuticals	Syrups, alcohol, glycerine, oils, sorbitol
Aviation	Filling/emptying of fuel and glycol	Workshops	Oil, coolants, waste oil
Paint Industry	Solvents, resin, paint, wood preservatives, varnish, stain, latex, acetone, turpentine	Water Industry	Polymers (flocculants), sludge, chemicals, sampling
Chemical Industry	Acids, alkalies, suspensions, stabilisers, resins, waste recovery, solvents, glues	Paper Industry	Ink, solvents, resin, dispersions, latex, glues
Cosmetics	Body/skin lotions, shampoo, soap emulsions, lotions, liquid soap	Refineries	Tank cleaning, oil sludge, petroleum
		Surface Treatment	Galvanic baths, solvents, acids, caustic soda, varnish
		Marine	Dewatering bilges and holds, sewage

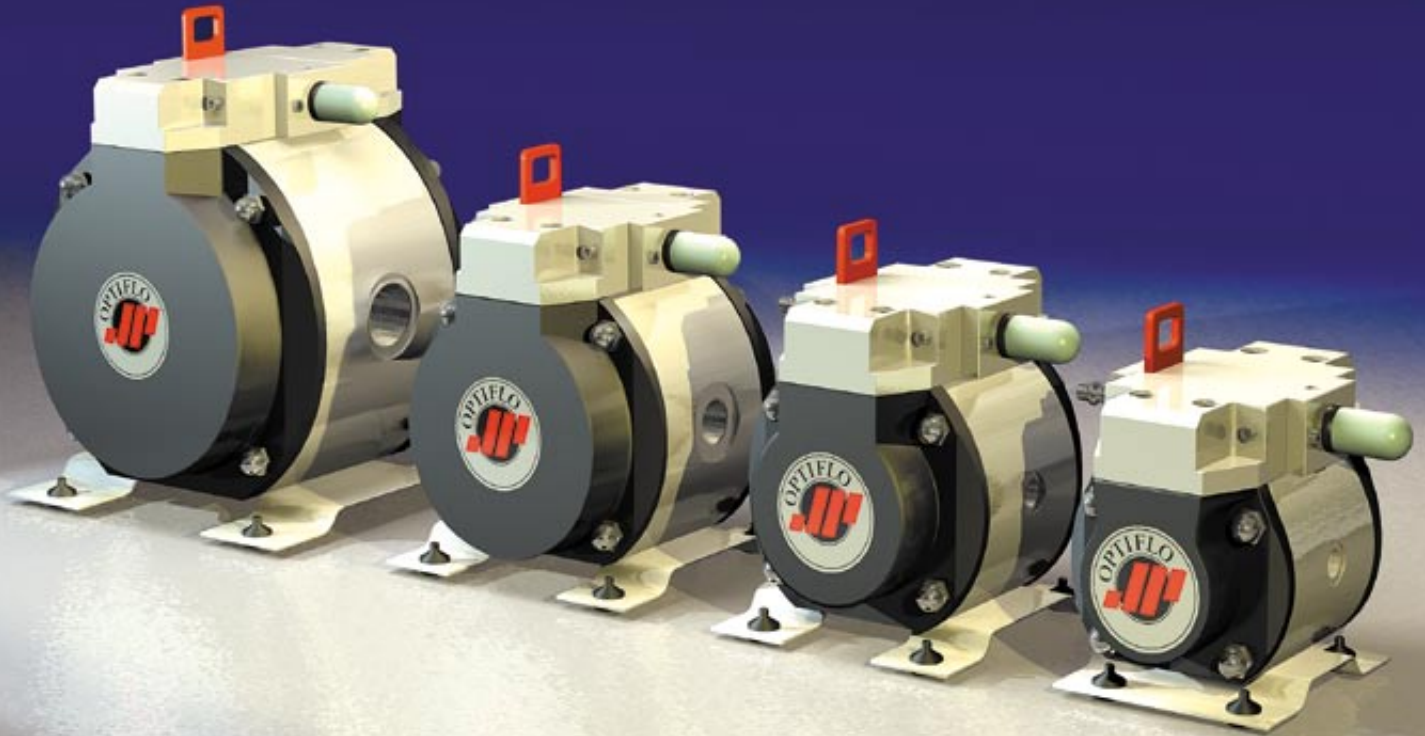

# Technical specifications

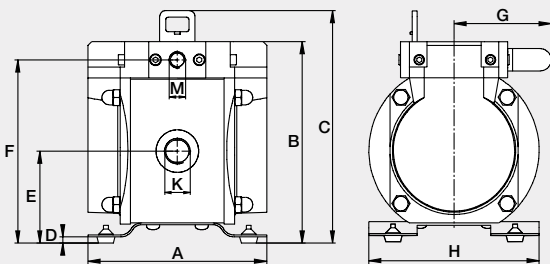

DIMENSIONS										
	A	B	C	D	E	F	G	H	K	M
OF 15	147	123	140	2.5	53	110	100	141	1/4"	3/8"
OF 30	147	145	170	2.5	64.5	130	100	141	3/8"	3/8"
OF 60	147	164	189	2.5	74	149	100	141	3/4"	3/8"
OF 120	178	210	235	2.5	97	195	100	184	1 1/4"	3/8"

TECHNICAL DATA				
DATA	OF 15	OF 30	OF 60	OF 120
Max capacity (l/min)	20	40	80	130
Max pump pressure (bar)	7	7	7	7
Max air pressure (bar)	7	7	7	7
Weight version PP/AL (kg)	1.8/2.5	2.7/3.7	3.6/4.9	6.9/9.8
<b>MATERIAL</b>				
Pump housing	PP or Al	PP or Al	PP or Al	PP or Al
Diaphragm	PTFE (standard) NBR, EPDM on request	PTFE (standard) NBR, EPDM on request	PTFE (standard) NBR, EPDM on request	PTFE (standard) NBR, EPDM on request

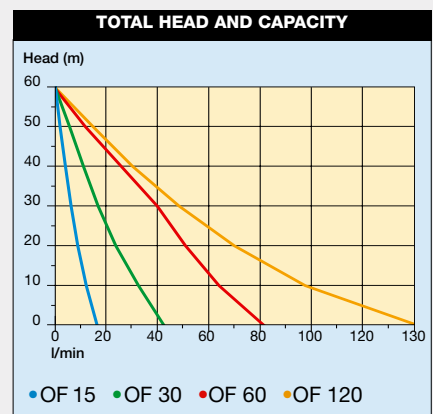



## Johnson Pump Group

### Parent Company

#### SWEDEN

Johnson Pump AB  
Tel. +46 (0)19 21 83 00  
Fax +46 (0)19 27 23 30

### National Sales Organisations

#### AUSTRALIA

Johnson Pump (Australia) Pty. Ltd.  
Tel. +61 (0)7 3899 9933  
Fax +61 (0)7 3899 8574

#### BELGIUM

Johnson Pump N.V./S.A.  
Belgium:  
Tel. +32 (0)2 422 15 50  
Fax +32 (0)2 422 15 59

#### DENMARK

Johnson Pumper A/S  
Tel. +45 43 52 24 00  
Fax +45 43 52 15 77

#### FINLAND

Johnson Pump Oy  
Tel. +358 (0)9 348 3800  
Fax +358 (0)9 348 38495

#### FRANCE

Johnson Pompes  
Tel. +33 (0)1 39 20 50 00  
Fax +33 (0)1 39 56 54 22

#### GERMANY

Johnson Pumpen GmbH  
Tel. +49 (0)5731 480 80  
Fax +49 (0)5731 414 00

#### ITALY

Johnson Pump Italiana S.r.l.  
Tel. +39 039 604 14 63  
Fax +39 039 604 90 97

#### NETHERLANDS

Johnson Pump B.V.  
Tel. +31 (0)592 37 67 67  
Fax +31 (0)592 37 67 06

#### Johnson Pump Horticulture

Tel. +31 (0)174 51 84 10  
Fax +31 (0)174 51 84 44

#### NORWAY

Johnson Pump A/S  
Tel. +47 22 74 08 40  
Fax +47 22 22 70 30

#### SPAIN

Johnson Pump España, S.L.  
Tel. +34 972 58 08 01  
Fax +34 972 58 08 03  
Sales Office:  
Madrid: Tel. +34 91 888 79 22

#### SWEDEN

Johnson Pump Svenska  
Tel. +46 (0)19 21 83 70  
Fax +46 (0)19 27 23 18

#### SWITZERLAND

Johnson Pumpen AG  
Tel. +41 (0)43 477 71 22  
Fax +41 (0)43 477 71 20

#### UNITED KINGDOM

JP Pumps Ltd.  
Tel. +44 (0)1293 55 34 95  
Fax +44 (0)1293 52 46 35  
Northern Regional Office:  
Bradford: Tel. +44 (0)1274 74 22 47  
Fax +44 (0)1274 74 22 28

### Business Units

#### BELGIUM

Johnson Pump Brussels N.V.  
Tel. +32 (0)53 60 27 15  
Fax +32 (0)53 60 27 01

#### INDIA

Johnson Pump (India) Ltd.  
Tel. +91 (0)79 2287 03 11  
Fax +91 (0)79 2287 25 22

#### NETHERLANDS

Johnson Pump Water B.V.  
Tel. +31 (0)592 37 67 67  
Fax +31 (0)592 37 67 60

#### SWEDEN

Johnson Pump AB  
Tel. +46 (0)19 21 83 00  
Fax +46 (0)19 27 23 72

#### USA

Johnson Pumps of America, Inc.  
Tel. +1 847 671 7867  
Fax +1 847 671 7909



*In addition to our own companies we are represented by independent distributors in over 50 countries worldwide.*

[www.johnson-pump.com](http://www.johnson-pump.com)



**JOHNSON PUMP**

Johnson Pump Italiana S.r.l.