

# TopAir – TA-40

## Persluchtgedreven Membraanpompen

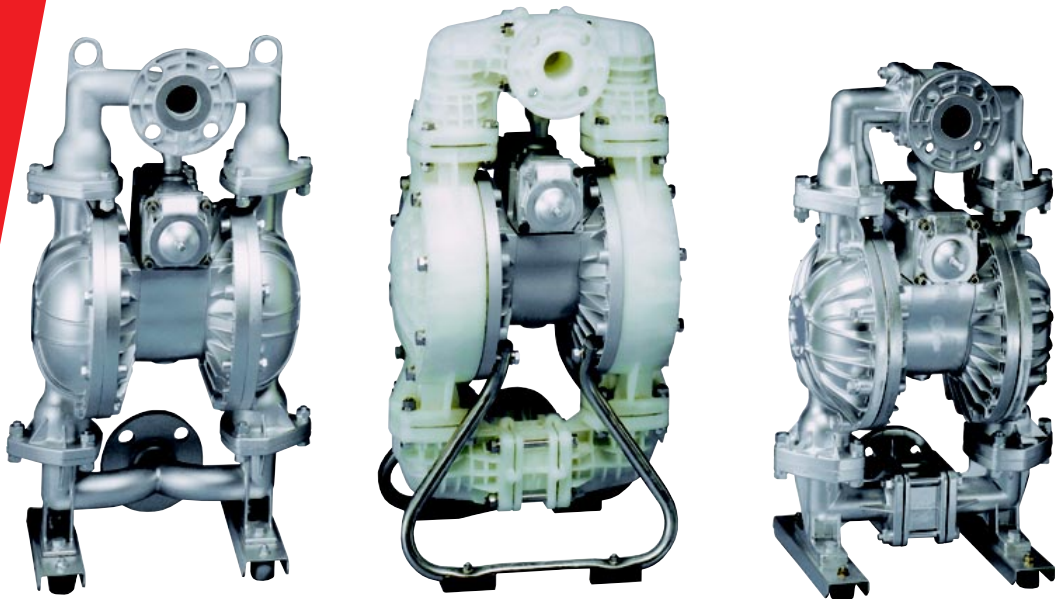

### Pompgegevens

#### Voorbeeld: TA-40 BPC

TA = TopAir  
40 = In- en uitgang, nominaal  
B = Kogelklep  
P = Materiaal natte delen  
C = Materiaal membranen

### Technische gegevens

#### Max. debiet

450 l/min

#### Aansluitingen

Vloeistof in- uitlaat: 1.1/2" DIN Flens (40 mm)  
Cast iron 1.1/2" BSP (40 mm)

Luchtinlaat: 1/2" BSPT (met kogelklep)  
Luchtuitlaat: Rc 1" (met muffler)

#### Slagvolume

Rubber membranen: 2.8 liter  
PTFE membranen: 1.4 liter

#### Maximale persluchtdruk

TA-40 BP\_: 0.2 - 0.5 MPa  
TA-40 BA\_, BS\_, BF\_: 0.2 - 0.7 MPa

#### Persluchtdruk

TA-40 BP\_: 0.5 MPa  
TA-40 BA\_, BS\_, BF\_: 0.7 MPa

#### Max. deeltjesgrootte

Kleiner dan 7 mm

#### Gewicht

TA-40 BA\_: 40 kg  
TA-40 BF\_: 62 kg  
TA\_40 BP\_: 27 kg  
TA-40 BS\_: 52 kg

### Materialen

Membranen	Natte delen			
	A: Aluminium	F: Cast iron	P: Polypropylene	S: Stainless steel
C: Neoprene® (CR)	TA-40 BAC	TA-40 BFC	TA-40 BPC	TA-40 BSC
N: Nitrile (NBR)	TA-40 BAN	TA-40 BFN	TA-40 BPN	TA-40 BSN
E: Nordel® (EPDM)	TA-40 BAE	TA-40 BFE	TA-40 BPE	TA-40 BSE
S: Santoprene® (TPO)	TA-40 BAS	TA-40 BFS	TA-40 BPS	TA-40 BSS
H: Hytrel® (TPEE)	TA-40 BAH	TA-40 BFH	TA-40 BPH	TA-40 BSH
V: Viton® (FPM)	TA-40 BAV	TA-40 BFV	TA-40 BPV	TA-40 BSV
T: Teflon® (PTFE)	TA-40 BAT	TA-40 BFT	TA-40 BPT	TA-40 BST

**Nota:** Kogelmateriaal voor Hytrel® membranen = Nitrile (NBR), voor Santopreen® pomp = Nordel® (EPDM).

# Afmetingen

**TA-40 BA\_, TA-40 BAT**

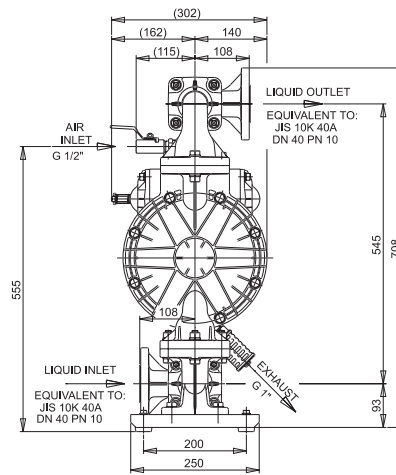
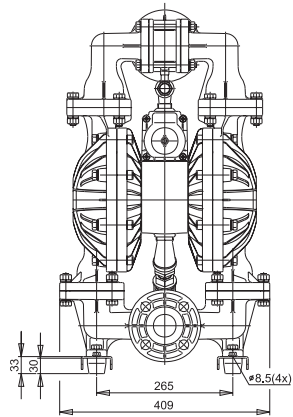

**TA-40 BS\_, TA-40 BST**

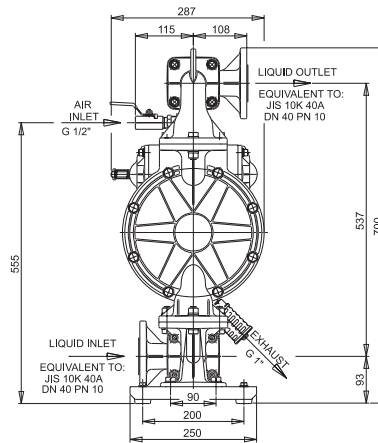
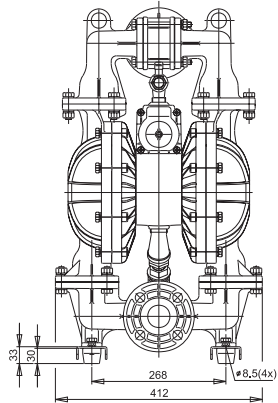

**TA-40 BP\_, TA-40 BPT**

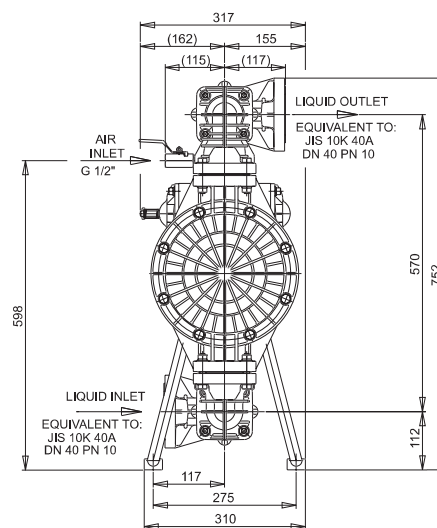
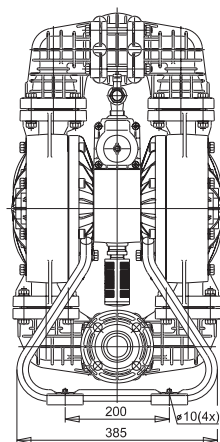

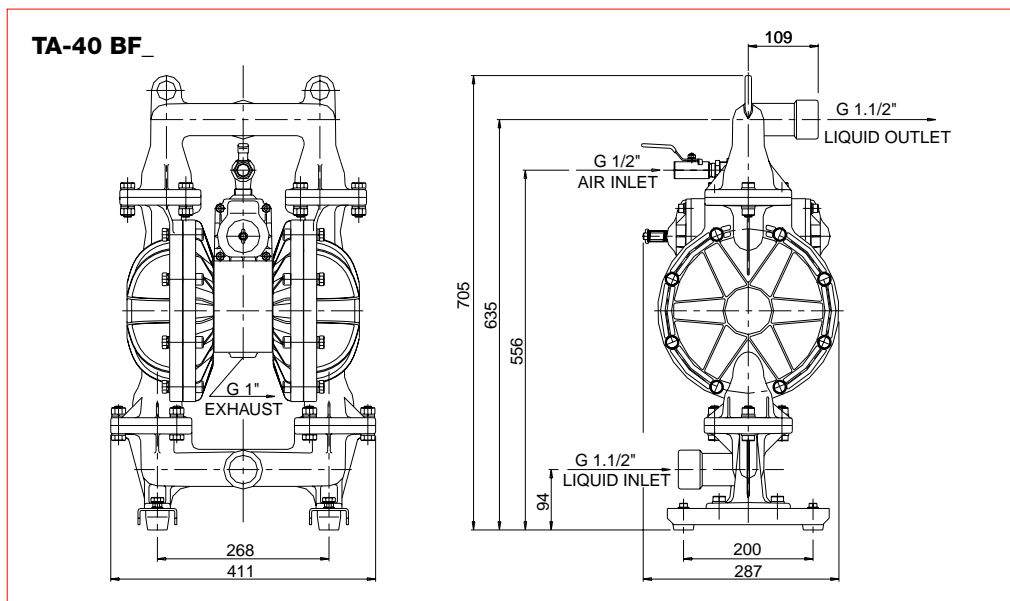

**Performance curves (gebaseerd op water bij 20°C)**

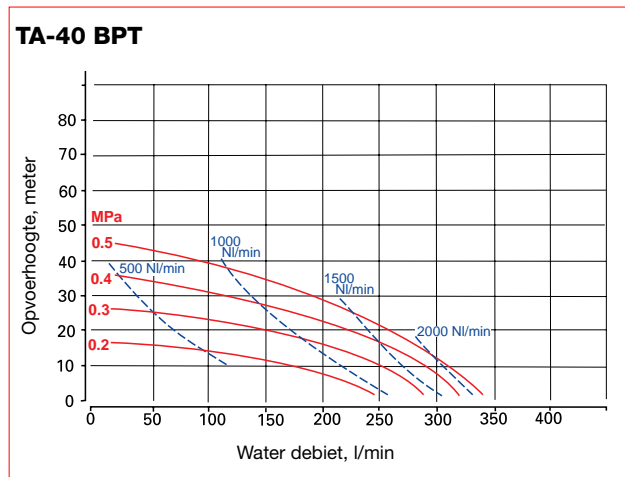
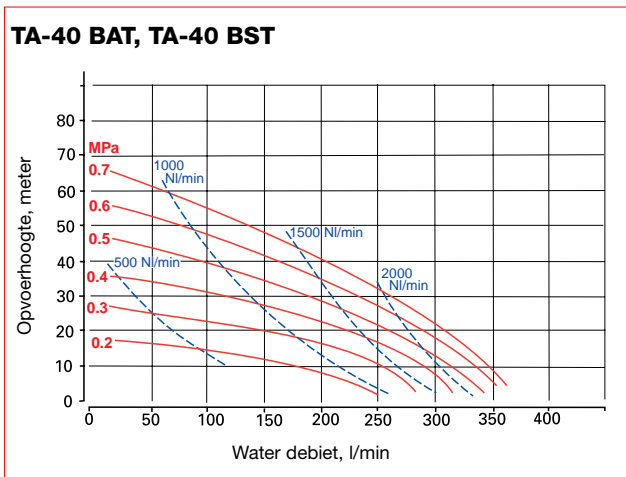
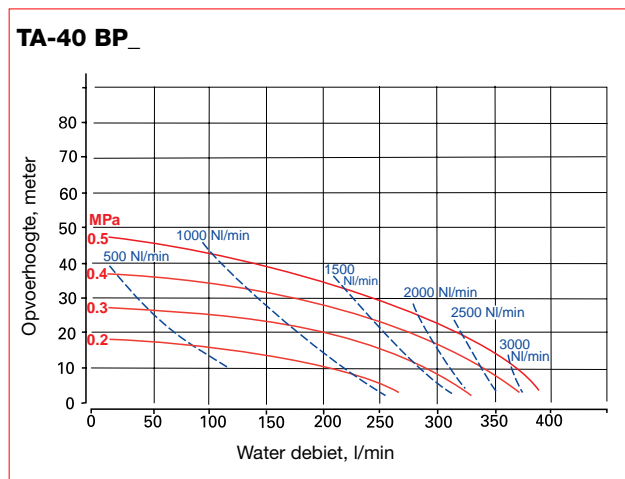
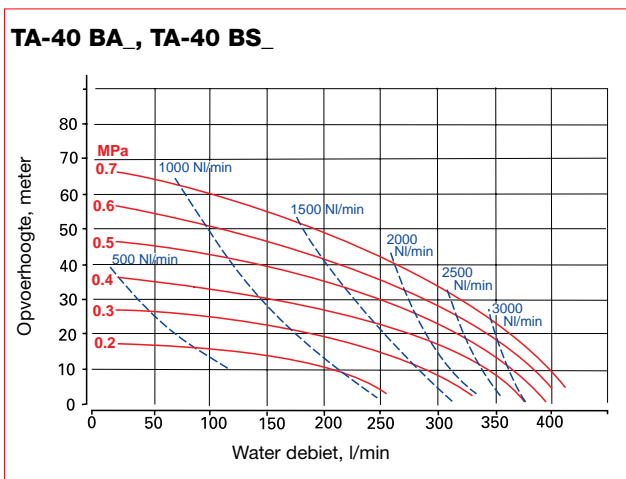

Om de beste levensduur voor membranen te garanderen, kies een pomp die 1,5 maal de gevraagde capaciteit aankan.

**Opgepast:** Persluchtdruk moet lager blijven dan 0.5 MPa voor PP, PTFE en PVDF pompen.



**JOHNSON PUMP**  
Johnson Pump Belgium N.V.

