

Tigerloop®

Model TN



No. S220 AUTOMATIC OIL DE-AERATOR

MAX. NOZZLE CAPACITY 20 GPH
 MAX. RETURN OIL FLOW* 30 GPH
 TEMPERATURE RANGE 20 -105° F
 MAX. INLET PRESSURE 8 PSI

FUEL No. 1 & 2 HEATING OIL, B5 BioHeat®
Not for use with E-diesel or any fuel containing Ethanol (alcohol)
 CONNECTIONS 1/4"- NPT
 APPROVAL UL LISTED

* Return oil flow from the burner pump to the Tigerloop® varies with pump model and RPM. To ensure that the maximum return flow to the Tigerloop® does not exceed 30 GPH, consult the burner pump manufacturer for return flow specs.



WARNING: INSTALLATION MUST BE PERFORMED BY A QUALIFIED TECHNICIAN FAMILIAR WITH OIL HEATING SYSTEMS, EQUIPPED WITH THE PROPER TOOLS AND EQUIPMENT, FAMILIAR WITH ALL GOVERNING CODES AND ORDINANCES, AND LICENSED BY THE PROPER AUTHORITY WHERE APPLICABLE. INSTALLATION BY AN UNQUALIFIED PERSON CAN RESULT IN HAZARDS TO THAT PERSON AND OTHERS. THESE HAZARDS MAY INCLUDE SPILLAGE OF FUEL OIL, FIRE, SEVERE BURNS, DAMAGE TO SYSTEM COMPONENTS, AND OTHER HAZARDS.

DESCRIPTION: The Tigerloop® makes it possible to use a one-pipe oil supply system on all standard oil heating installations. It safely handles minor air leaks and long piping runs, while eliminating the return line with its potential for environmental problems.

INSTALLATION: The Tigerloop® should be installed indoors and close to the burner in a dry area with a temperature range of between 20° F and 105° F. Since the Tigerloop® must be securely mounted vertically (see illustrations), the use of the supplied mounting bracket, securely attached to a suitably strong surface, is recommended. Never use the Tigerloop® as a structural member to support long, heavy runs of piping. If the tank is located above the Tigerloop®, an oil safety valve (ie. Westwood Products No. S225) is strongly recommended. If the inlet pressure will exceed 8 PSI, an oil safety valve **must be installed**. On installations with more than one oil burner, **each oil burner must have its own Tigerloop®**, which may be teed into a common inlet line from the tank. The following procedure must be used to insure proper operation and to avoid fuel releases that can harm the environment and service personnel.

1. Eye protection and heating oil resistant gloves must be worn.
2. Inspect the entire fuel system to insure that all components are in good condition and that the system conforms to all applicable codes and ordinances. Correct any problems before proceeding with the installation.
3. Turn off all power to the heating system and close all oil line valves. Use a voltmeter to verify that the power is off.
4. Place an oil resistant container under the place where the Tigerloop® is to be installed and oil absorbent material in the work area to catch any fuel releases.
5. Securely attach the mounting bracket to a suitably strong surface such that the Tigerloop® will be oriented vertically and plumb (see illustration 1).
6. The Tigerloop® has three 1/4"-NPT ports that are marked with arrows to show oil flow direction. Ports "A" and "B" (see illustration 2) connect to the oil burner pump and are located on one side. The "Tank Port", which connects to the oil line from the tank, is located on the bottom (see illustration 2). All fittings should be installed in the Tigerloop® before attaching it to the mounting bracket. A good quality, non-hardening pipe compound must be used on all pipe threads (do not use Teflon tape). If connection is to copper tubing, flare fittings must be used for all tubing connections (do not use compression fittings). Since the Tigerloop® is UL Listed, the fusible valve that comes packed with it **must be installed** in the "Tank Port".
7. To accommodate the layout of the installation, the Tigerloop® may be mounted with ports "A" and "B" facing either left or right, depending upon which mounting boss is used to attach it to the mounting bracket. Carefully insert the mounting boss into the top of the slot in the mounting bracket and continue to push the Tigerloop® down until it snaps into place.
8. Set the oil burner pump for *two-pipe* operation (install a by-pass plug if necessary) and connect port "A" to the return port of the oil burner pump. Connect port "B" to the inlet port of the oil burner pump. *Note: Do not install any filters, valves, or other devices that can impede oil flow in the lines between the Tigerloop® and the oil burner pump!* (A fusible valve in the inlet port of the pump is permitted if required by code.)
9. Install an oil filter in the oil line from the tank. Connect the outlet of the oil filter to the fusible valve in the "Tank Port". *Note: All filters must be upstream of the Tigerloop® and cannot be in the lines between the Tigerloop® and the oil burner pump!*
10. Complete the Tigerloop® Installation Check List shown on this page to insure compliance with installation requirements. Open all oil line shut-off valves, restore power, and operate the system. Bleeding the oil burner pump is not necessary if the supply line leading from the tank to the Tigerloop® is **not** run overhead; the Tigerloop® will self-bleed. For bleeding overhead supply line installations, see "**OVERHEAD LINES**", below. During system operation, inspect to insure that there are no leaks, that the system is working properly, and that there is no oil in the upper chamber of the Tigerloop® (oil in the upper chamber means the Tigerloop® is damaged and must be replaced). *Note: The oil level in the lower chamber of the Tigerloop® may vary with changing conditions on the job. For example, the air pocket may slowly disappear until the lower chamber is completely filled with oil. This is not a problem, the Tigerloop® is functioning properly. As conditions change, an air pocket may again appear.*
11. Clean up the work area and properly dispose of all liquid fuel oil and used absorbent materials and refuse in accordance with applicable regulations.

SERVICE: The Tigerloop® has no serviceable parts inside. It is sealed at the factory and cannot be opened without destroying it. Clean the outside with a dry cloth only. *Do not use cleaning chemicals or any liquids containing alcohol!* Since the Tigerloop® is exposed to modern fuels and fuel blends that may contain additives and contaminants, a reliable service life of 8 years is considered maximum. Use of the Tigerloop® beyond that time exposes the system to risk of component failure leading to fuel leakage, fire hazard, and environmental damage.

OVERHEAD LINES: Overhead supply lines should be avoided whenever possible as they cause increased air purging problems. If unavoidable, the following is recommended: Vertically descending piping in the burner area should terminate with an elbow into a ball valve at approximately the same height as the Tigerloop®. The filter should be installed into the outlet of the ball valve using a shoulder nipple. From the outlet of the filter, the oil line (copper tubing or flexible oil line) should drop down 12" and then run up again into the fusible valve in the Tigerloop® "Tank Port". The path of the oil line between the filter and the Tigerloop® should be a smooth, circular arc with no sharp bends. On initial start-up, open the ball valve, start the burner, and open the pump bleeder. When air free oil has been flowing from the bleeder for at least one minute, close the ball valve. When little or no oil flows from the bleeder, open the ball valve. When air free oil again flows from the bleeder for at least one minute, close the bleeder and stop the burner. The system is now ready for operation.

1

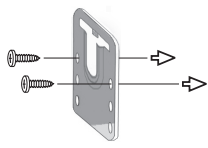

Mount Bracket

2

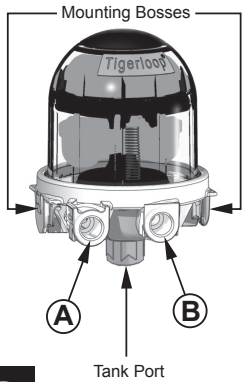

Connection Port Identification

For illustration clarity, fittings are not shown installed in the Tigerloop®

3

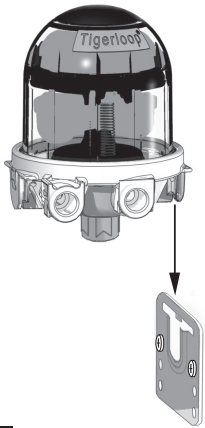

Attach Tigerloop® to Bracket

Tigerloop® Installation Check List

- Oil is No. 1 or No. 2 heating oil.
- One Tigerloop® for each burner.
- Installed in an upright position in an area not above 105° F.
- Inlet pressure not above 8 PSI.
- Oil filter installed in the oil line before the Tigerloop®.
- Fusible valve installed in the "Tank Port" of Tigerloop®.
- No valves, filters, etc., installed in piping between the Tigerloop® and the oil burner pump.
- Pump set for two-pipe operation. (by-pass plug installed if needed)

Tigerholm

AN SPX BRAND

Westwood

Westwood Products Inc. South River, NJ 08882

Tigerloop®

ULTRA



No. S220-8 COMBINATION OIL DE-AERATOR & HIGH EFFICIENCY SPIN-ON FILTER

MAX. NOZZLE CAPACITY 20 GPH
 MAX. RETURN OIL FLOW* 30 GPH
 TEMPERATURE RANGE 20° - 105° F
 MAX. INLET PRESSURE 8 PSI
 FUEL No. 1 & 2 HEATING OIL, B5 BioHeat® *Not for use with E-diesel or any fuel containing Ethanol (alcohol)*

CONNECTIONS 1/4"- NPT
 REPLACEMENT ELEMENT F100-10
 ELEMENT SPECS 10 Micron/EPOXY COATED INSIDE
 APPROVAL UL LISTED

* Return oil flow from the burner pump to the Tigerloop® varies with pump model and RPM. To ensure that the maximum return flow to the Tigerloop® does not exceed 30 GPH, consult the burner pump manufacturer for return flow specs.

WARNING: INSTALLATION MUST BE PERFORMED BY A QUALIFIED TECHNICIAN FAMILIAR WITH OIL HEATING SYSTEMS, EQUIPPED WITH THE PROPER TOOLS AND EQUIPMENT, FAMILIAR WITH ALL GOVERNING CODES AND ORDINANCES, AND LICENSED BY THE PROPER AUTHORITY WHERE APPLICABLE. INSTALLATION BY AN UNQUALIFIED PERSON CAN RESULT IN HAZARDS TO THAT PERSON AND OTHERS. THESE HAZARDS MAY INCLUDE SPILLAGE OF FUEL OIL, FIRE, SEVERE BURNS, DAMAGE TO SYSTEM COMPONENTS, AND OTHER HAZARDS.

DESCRIPTION: The ULTRA™ combines the Tigerloop® Oil De-Aerator with the Westwood Products premium Ultra-10™ (10 micron) high efficiency spin-on filter element. This combination provides the ultimate in fuel conditioning for oil heating systems.

INSTALLATION: The ULTRA™ should be installed indoors and close to the burner in a dry area with a temperature range of between 20° F and 105° F. Since the ULTRA™ must be securely mounted vertically (see illustrations), the location must provide a suitably strong surface on which to attach the mounting bracket. **The mounting bracket must be used! The ULTRA™ cannot be mounted using piping only!** If the tank is located above the ULTRA™, an oil safety valve (ie. Westwood Products No. S225) is strongly recommended. If the inlet pressure will exceed 8 PSI, an oil safety valve **must be installed**. On installations with more than one oil burner, **each oil burner must have its own ULTRA™**, which may be teed into a common inlet line from the tank.

The following procedure must be used to insure proper operation and to avoid fuel releases that can harm the environment and service personnel.

1. Eye protection and heating oil resistant gloves must be worn.
2. Inspect the entire fuel system to insure that all components are in good condition and that the system conforms to all applicable codes and ordinances. Correct any problems before proceeding with the installation.
3. Turn off all power to the heating system and close all oil line valves. Use a voltmeter to verify that the power is off.
4. Place an oil resistant container under the place where the ULTRA™ is to be installed and oil absorbent material in the work area to catch any fuel releases.
5. Securely attach the mounting bracket to a suitably strong surface such that the ULTRA™ will be oriented vertically and plumb (see illustration 1).
6. The ULTRA™ has three 1/4"-NPT ports that are marked with arrows to show oil flow direction. Ports "A" and "B" (see illustration 2) connect to the oil burner pump and are located on one side. The "Tank Port", which connects to the oil line from the tank, is located on the other side (not visible in illustration 2). All fittings should be installed in the ULTRA™ before attaching it to the mounting bracket. A good quality, non-hardening pipe compound must be used on all pipe threads (do not use Teflon tape). If connection is to copper tubing, flare fittings must be used for all tubing connections (do not use compression fittings). Since the ULTRA™ is UL Listed, the fusible valve that comes packed with it **must be installed** in the "Tank Port".

7. Attach the ULTRA™ to the mounting bracket using the screws supplied (see illustration 2). To accommodate the layout of the installation, it may be mounted with the "Tank Port" facing either left or right, depending upon which holes are used to attach it to the mounting bracket.
8. Set the oil burner pump for *two-pipe* operation (install a by-pass plug if necessary) and connect port "A" to the return port of the oil burner pump. Connect port "B" to the inlet port of the oil burner pump. *Note: Do not install any filters, valves, or other devices that can impede oil flow in the lines between the ULTRA™ and the oil burner pump! (A fusible valve in the inlet port of the pump is permitted if required by code.)*
9. Connect the oil line from the tank to the fusible valve in the "Tank Port".
10. Install the O-ring provided with the spin-on element on the threaded post on the bottom of the ULTRA™. Lubricate

the surface of the spin-on element gasket with clean heating oil. Thread the spin-on element onto the threaded post and turn clockwise an additional 1/4 to 1/2 turn after the gasket makes contact with the ULTRA™.

11. Complete the Tigerloop® Installation Check List shown on the opposite side of this page to insure compliance with installation requirements. Open all oil line shut-off valves, restore power, and operate the system. Bleeding the oil burner pump is not necessary if the supply line leading from the tank to the ULTRA™ is **not** run overhead; the ULTRA™ will self-bleed. For bleeding overhead supply line installations, see "OVERHEAD LINES", below. During system operation, inspect to insure that there are no leaks, that the system is working properly, and that there is no oil in the upper chamber of the ULTRA™ (oil in the upper chamber means the ULTRA™ is damaged and must be replaced). *Note: The oil level in the lower chamber of the ULTRA™ may vary with changing conditions on the job. For example, the air pocket may slowly disappear until the lower chamber is completely filled with oil. This is not a problem, the ULTRA™ is functioning properly. As conditions change, an air pocket may again appear.*

12. Clean up the work area and properly dispose of all liquid fuel oil and used absorbent materials and refuse in accordance with applicable regulations.

SERVICE: Replace the filter element at the beginning of each heating season. For easy filter element removal, use a spin-on filter wrench (ie. Westwood Products No. F100-18) and an adjustable wrench (see illustration 4). The Tigerloop® itself has no serviceable parts inside. It is sealed at the factory and cannot be opened without destroying it. Clean the outside with a dry cloth only. *Do not use cleaning chemicals or any liquids containing alcohol!* Since the Tigerloop® is exposed to modern fuels and fuel blends that may contain additives and contaminants, a reliable service life of 8 years is considered maximum. Use of the Tigerloop® beyond that time exposes the system to risk of component failure leading to fuel leakage, fire hazard, and environmental damage.

OVERHEAD LINES: Overhead supply lines should be avoided whenever possible as they cause increased air purging problems. If unavoidable, the following is recommended: Vertically descending piping in the burner area should terminate into a ball valve at approximately the same height as the ULTRA™. From the outlet of the ball valve, the oil line (copper tubing or flexible oil line) should drop down 12" and then run up again into the fusible valve in the ULTRA™ "Tank Port". The path of the oil line between the ball valve and the ULTRA™ should be a smooth, circular arc with no sharp bends. On initial start-up, open the ball valve, start the burner, and open the pump bleeder. When air free oil has been flowing from the bleeder for at least one minute, close the ball valve. When little or no oil flows from the bleeder, open the ball valve. When air free oil again flows from the bleeder for at least one minute, close the bleeder and stop the burner. The system is now ready for operation.

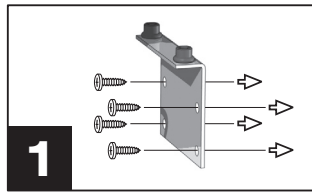

Mount Bracket

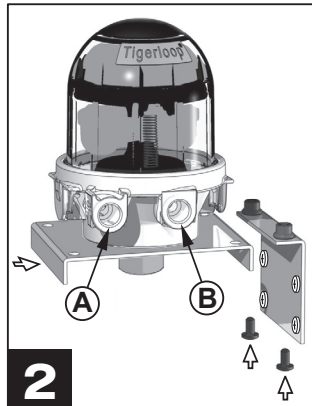

Attach Tigerloop to bracket

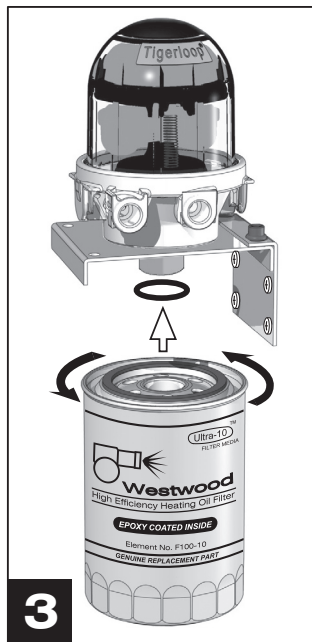

Mount spin-on element



Spin-on element removal

For illustration clarity, fittings are not shown installed in the Tigerloop®

Tigerholm

AN SPX BRAND

Westwood

Westwood Products Inc. South River, NJ 08882